



---

## **Integrated of Machining Operation Sequences and Cutting Tools Selection Based Artificial Neural Network for Rotational Parts**

Dr. Amjad Barzan Abdulghafour<sup>a</sup>, Mrs. Zaineb Hameed Neama<sup>b\*</sup>

<sup>a,b</sup>*Production and Metallurgy Engineering Department, University of Technology, Baghdad-Iraq*

<sup>a</sup>*Email: Amjad\_barzan@yahoo.com*

<sup>b</sup>*Email: zainebhameed1993@gmail.com*

### **Abstract**

Process planning is a central, knowledge extensive and important activity in a manufacturing company. The selection of machining operations sequence and cutting tools are important tasks in process planning. In this paper, the main aim is to develop an integrated process planning and artificial neural networks that can automatically perform the task of process planning for rotational parts . The proposed method consists of two modules; the first module NN1 for selection of machining operations sequence based on feature type and their attribute include dimensional, tolerance, and surface finish by pre-structure of thumb rule and neural network were employed for automated CAPP. The second module NN2 for cutting tool selection based on the type, condition and dimensional ratio of feature, so the NN1 outputs as parameter of input layer for NN2. The methods of training, testing and validation of the network have been used back propagation . Case study has found that the developed system is able to give best prediction solutions for process planning problems so, the proposed approach to explain its selection of machining operation sequences and cutting tools for using in real manufacturing environment.

**Keywords:** Neural Network; Operation Selection; Operation Sequence; Cutting Tools Selection; Process Planning; Thumb Rule.

---

\* Corresponding author.

## **1. Introduction**

Process Planning is defined as the planning and development of detailed instructions for the conversion of a raw material into a finished part based on some feasible engineering design. Process planning includes the activities and functions to get ready a detailed set of plans. It includes operations sequence, selection of raw material, machines, tools, cutting tools and machine parameters, etc. There are two basic approaches to automated process planning: the variant approach each part is classified based on a number of attributes and coded using a classification and coding system. The code and process plan for each part are stored in a data base. When it is required to generate a process plan for a new part, the part is coded and a process plan for a part similar to the new part is retrieved from the data base. The variant approach might be useful in a case where there is a great deal of the similarity between parts and might be useful in a case where there is a great deal of the similarity between parts. In the generative approach, there are no process plan stored in the data base. Instead, the data base contains information about parts, machines, tooling, and process planning rules. Using the information, a generative process planning system creates the process plan required. Existing generative process planning systems can generate process plans for parts with rather simple geometry [1]. Artificial Intelligence and specifically expert systems (ES) have been used to design generative process planning systems [2]. Some of process planning knowledge relies on many of heuristic knowledge from the process planner. Artificial Neural Networks (ANN) offer a promising solution in the area of mapping the manufacturing features of a component to a sequence of machining operations [3]. Artificial neural network is a mathematical model in order for parallel computing mechanisms after biological brain. Neural networks are the techniques developed by simulating the human neuron function and using weights distributed among their neurons to perform implicit inferences. The function of a neural network-based system is determined by four parameters: net topology, training or learning rules, input node and output node characteristics [4]. Artificial neural network has been widely used in engineering application domain, especially for design and manufacturing. Networks learn relationships between input and output by iteratively changing interconnecting weight values until the outputs over the problem domain represent the desired relationship [5]. ANNs an effective tool for some typical problems of process planning [6]. The aim of this paper is to develop an integrated process planning and artificial neural networks that can automatically perform the task of machining operation sequences and cutting tools selection for rotational parts to help designers and process planners to improve their design and planning in the early stages of the product life cycle. The rest of the paper is organized as follows: Section 2 presents the review of relevant literature on neural network in CAPP. Section 3 describes the neural network based methodology developed for selection of machining operations for rotational parts. In section 4 present the case study and their results. In Section 5 Conclusions from this research work. **BenKhalifa et.al [7]** applied neural networks approach in the task of generating process planning for machining features. Two cooperated neural networks NN1 and NN2 are used for selection of machine tools according to machining features proposed. The first neural network takes in input the attributes of machining features and produces the suitable classes of machine tools, the second neural networks used for optimization of machine tools selection is according to machining workshop capacity. Ahmed and his colleagues [4] Artificial Neural Network is used feed forward architecture three layer network for process selection and process sequencing in surface machining of cylindrical components and this categorization task for its capability of continued learning

throughout the life of the system and ability to learn arbitrary mappings between input and output spaces. Here a cylindrical part features with their attributes are input, while the output is the operations required to produce each feature and the sequences of the operations. Devireddy and his colleagues [8] employed a three-layer, back-propagation neural network for selection of machining operations for all the features at a time, by taking into consideration the global operations sequence across all the features of a part. This approach is able to overcome some limitations of decision trees and expert system based approaches". Deb and his colleagues [9] used the back-propagation neural network method for the selection of all possible operations for machining rotationally symmetrical parts. This was done by pre-structuring the neural network with prior domain knowledge in the form of thumb rules . Amaitik and his colleagues [10] developed a process planning system for prismatic parts by developed several neural network models. The main neural network model is used to select proper cutting tool for each machining feature. The idea that is for each machining feature and machining operation combination there is a corresponding cutting tool to be used to create that feature . The neural network is trained based on this method. For each cutting tool, a neural network was designed and trained to select the proper tool geometry. Selection of a machine tool on which the machining operations can be performed to produce the given part is also implemented by a neural network. The input vector of the neural network includes machining part characteristics and machining operation characteristics, and the output vector of the neural network contains recommended specifications of the machine tool to be used". Rana and his colleagues [11] used Neural Network as a global for a quick symmetry of optimal operation sequence for rotational parts. Operation sequencing in Process Planning is interest with the machining operations selection in steps that can produce each form feature of part by directs relevant technological constraints specified in drawing. AS revealed in the literature presented above, based neural networks for machining operations selection in CAPP systems. In this paper the neural network has been developed by pre-structured with the form of heuristic or thumb rules for machining operation sequence . **Izabela rojek [3]** presented neural networks as models for classification in intelligent CAPP systems. For the construction of classification models, three types of neural networks were used: linear network, multilayer network with error back propagation (MLP), and radial basis function network (RBF). The classification models were compared for their ability to produce the best classification. Classification models were constructed for tool selection for selected manufacturing operations: turning, milling, and grinding. The models for milling were presented in detail .

## **2. Proposed methodology**

In this research developed a new methodology consists of two modules for process planning tasks to carry out the experiments by selecting different variables and their parameters by applying artificial neural network and then analyzing the results obtained. The flowchart of the proposed methodology is shown in Figure (1). First module is called NN1 for machining operations and their sequence, developed by pre-structure of thumb rule and ANN for selection of machining operation sequences based on each feature and their attributes in the rotational part, and then the outputs of machining operation sequence are employed as a parameter of input layer for NN2. The second module is represented by NN2 for cutting tools selection based on the type, condition and dimensional ratio of feature, so the outputs of NN1. The detailed strategy for building the neural network modules including designing, training and validation of the neural network is outlined . The main steps of the proposed methodology for two modules that will be discussed in the following sections:



**Figure 1:** The flowchart of the proposed methodology

- (a) Collect data
- (b) The thumb rules formulating for NN1.
- (c) Preparation samples

- (d) Normalization and division data.
- (e) Topology design of the network,
- (f) Training and validation and testing of the neural network.
- (g) Searching the cutting tools database for NN2.

**2.1 Collect data**

In order to develop a prediction system using ANN, the related dataset will be collected as the training datasets for the ANN. The researcher worked to understand and joined the modules according to the features, operations and tools. The data are taken from the Handbook [12-15] and made them by a great effort to collect and develop it for rearranging, framing and displaying them. The different features considered in this work and their ranges of dimensions, tolerances and surface finish are given in Table (1) and feasible operations for machining different features in rotational parts given in Table (2). Cutting tool data illustrated in Table (3)

**Table 1:** Different range of feature attributes

Feature type	Dimensions (mm)	Tolerance (mm)	Surface finish (µm)
Hole	Up to 50 (L/D Ratio up to 10)	0.003–3.90	0.04–80
External Taper	Up to 50	0.004–3.90	0.08–80
External Step	Up to 50	0.004–3.90	0.08–80
Groove	Up to 50	0.40–2.50	2.5–20
Face	Up to 50	0.010–3.90	1.25–80
External Thread	Up to 50	0.010–3.90	1.25–80

**Table 2:** Feasible operations of different feature

Feature type	Operation sequence	Feature type	Operation sequence
Hole	Drill	External	Turn
	Drill-Ream		
	Drill-Bore	Step	Turn-Grind
	Drill-Bore-Grind	Groove	Groove Turning
	Drill-Bore-Hone	Face	Turn
External Taper	Turn	Thread	Turn-Threading
	Turn-Grind		

**Table 3:** Cutting tool data

Feature name	Process	Tool geometry	Tool type	Tool Code
Hole	Drilling	$\varnothing = 0.30-0.45$ mm $\varnothing$ : diameter	Drilling tool	T1
Hole	Drilling	$\varnothing = 0.60-0.75$ mm $\varnothing$ : diameter	Drilling tool	T2
⋮	⋮	⋮	⋮	⋮
External step	Turning	Nose radius= 1.2 S: square $\theta = 95$ Angle: $\theta$	Turning tool	T14
⋮	⋮	⋮	⋮	⋮
Groove	Grooving	Width: 0.1-0.25 mm	Grooving tool	T19
Face	Facing	$\theta = 90$ Angle: $\theta$	Facing tool	T20
⋮	⋮	⋮	⋮	⋮
Thread	Threading	Left tool	Threading tool	T26

## 2.2 The thumb rules formulating

A set of rules has been developed to define the feature of part, feature attributes and for selection machining operation and their sequence for each feature. This methodology developed NN1 by pre-structuring of ANN and the form of heuristic called thumb rule. Thumb rule used as guidelines for choosing and preparation input and output pattern of training examples, it is important reduce complexity of learning, less cost . The domain knowledge for formulating the above rules was collated from machining handbooks and textbooks [15-18].The rules are formed in IF-THEN.

In the 'IF' part of the rule represents the input of NN1 includes (feature type and different range of feature attributes) and in the 'THEN' part of the rule represents the output of NN included machining operation and their sequence of each feature. The thumb rules are expressed in the following form:

IF (Feature is of the type) AND (Dimension of the feature), AND (Tolerance of the feature), AND (Surface finish of the feature), THEN (Operation sequence) . For example thumb rule of hole:

IF Diameter is 0-3 mm AND Tolerance is 0.02-0.09 mm AND Surface finish is 5-80  $\mu\text{m}$  THEN Operation

Sequence is Drill

IF Diameter is 0-3 mm AND Tolerance is 0.002-0.011 mm AND Surface finish is 0.16-5  $\mu\text{m}$  THEN Operation Sequence is Drill-Ream.

IF Diameter is 0-3mm AND Tolerance is 0.003-0.011 mm AND Surface finish is 0.08-2.5  $\mu\text{m}$  THEN Operation Sequence is Drill-Bore-Grind

IF Diameter is 0-3 mm AND Tolerance is 0.002-0.07 mm AND Surface finish is 0.04-1.25  $\mu\text{m}$  THEN Operation Sequence is Drill-Bore-Hone

IF Diameter is 3-6 mm AND Tolerance is 0.05-0.15 mm AND Surface finish is 5-80  $\mu\text{m}$  THEN Operation Sequence is Drill

IF Diameter is 3-6 mm AND Tolerance is 0.005-0.022 mm AND Surface finish is 0.16-5  $\mu\text{m}$  THEN Operation Sequence is Drill-Ream

IF Diameter is 3-6 mm AND Tolerance is 0.010-0.15 mm AND Surface finish is 0.63-20  $\mu\text{m}$  THEN Operation Sequence is Drill-Bore

IF Diameter is 3-6 mm AND Tolerance is 0.005-0.022 mm AND Surface finish is 0.08-2.5  $\mu\text{m}$  THEN Operation Sequence is Drill-Bore-Grind

IF Diameter is 3-6 mm AND Tolerance is 0.003-0.010 mm AND Surface finish is 0.04-1.25  $\mu\text{m}$  THEN Operation Sequence is Drill-Bore-Hone

IF Diameter is 6-10 mm AND Tolerance is 0.08-0.21 mm AND Surface finish is 5-80  $\mu\text{m}$  THEN Operation Sequence is Drill

IF Diameter is 6-10 mm AND Tolerance is 0.008-0.033 mm AND Surface finish is 0.16-5  $\mu\text{m}$  THEN Operation Sequence is Drill-Ream

IF Diameter is 6-10 mm AND Tolerance is 0.015-0.21 mm AND Surface finish is 0.63-20  $\mu\text{m}$  THEN Operation Sequence is Drill-Bore

IF Diameter is 10-18 mm AND Tolerance is 0.018-0.27 mm AND Surface finish is 0.63-20  $\mu\text{m}$  THEN Operation Sequence is Drill-Bore

IF Diameter is 10-18 mm AND Tolerance is 0.008-0.043 mm AND Surface finish is 0.08-2.5  $\mu\text{m}$  THEN Operation Sequence is Drill-Bore-Grind

IF Diameter is 10-18 mm AND Tolerance is 0.005-0.018 mm AND Surface finish is 0.04-1.25  $\mu\text{m}$  THEN Operation Sequence is Drill-Bore-Hone

IF Diameter is 18-30 mm AND Tolerance is 0.13-0.33 mm AND Surface finish is 5-80  $\mu\text{m}$  THEN Operation Sequence is Drill

IF Diameter is 18-30 mm AND Tolerance is 0.013-0.052 mm AND Surface finish is 0.16-5  $\mu\text{m}$  THEN Operation Sequence is Drill-Ream.

IF Diameter is 18-30 mm AND Tolerance is 0.021-0.33 mm AND Surface finish is 0.63-20  $\mu\text{m}$  THEN Operation Sequence is Drill-Bore

IF Diameter is 18-30 mm AND Tolerance is 0.009-0.052 mm AND Surface finish is 0.08-2.5  $\mu\text{m}$  THEN Operation Sequence is Drill-Bore-Grind

IF Diameter is 18-30 mm AND Tolerance is 0.006-0.021 mm AND Surface finish is 0.04-1.25  $\mu\text{m}$  THEN Operation Sequence is Drill-Bore-Hone

IF Diameter is 30-50 mm AND Tolerance is 0.011-0.062 mm AND Surface finish is 0.08-2.5  $\mu\text{m}$  THEN Operation Sequence is Drill-Bore-Grind

IF Diameter is 30-50mm AND Tolerance is 0.007-0.025 mm AND Surface finish is 0.04-1.25  $\mu\text{m}$  THEN Operation Sequence is Drill-Bore-Hone

IF Diameter is 18-30 mm AND Tolerance is 0.012-0.042 mm AND Surface finish is 0.15-5  $\mu\text{m}$  THEN Operation Sequence is Drill-Ream.

IF Diameter is 18-30 mm AND Tolerance is 0.031-0.43 mm AND Surface finish is 0.53-20  $\mu\text{m}$  THEN Operation Sequence is Drill-Bore

IF Diameter is 18-30 mm AND Tolerance is 0.008-0.052 mm AND Surface finish is 0.05-2.5  $\mu\text{m}$  THEN Operation Sequence is Drill-Bore-Grind

### ***2.3 Input and output variables of neural network***

Input layer for NN1 module that consists of node for type of feature and one node for each feature attributes (dimensional, tolerance and surface finish), dimensional of the feature expressed in (mm), tolerance expressed in (mm) and surface finish expressed in ( $\mu\text{m}$ ). The crisp values of these four variables representation in the input vector of the network has four columns, all value in input layer must be normalized between 0-1 .For example, for a hole (represented by 1 in column 1) of diameter 3 mm in column 2, tolerance 0.03mm in column 3 and surface finish 0.02 $\mu\text{m}$  in column 4, it is the following input vector of input layer is shown in Table (4). The same manner for NN2 module input layer that consists of node for type of feature and one node for each condition and dimensional ratio of feature.



**Table 4:** Input vector of input layer

Column number	1	2	3	4
Value	1	3	0.03	0.02

For example, typical input regarding a hole feature can be: '1 0 0 0 50 0.05 1.60'. This represents that the feature is a hole, it has a dimensional of 50 mm, a tolerance requirement of 0.05 mm and surface finish requirement of 1.60. The input values corresponding to the attributes dimensional, tolerance and surface finish are scaled appropriately to be in the range between 0 and 1, to facilitate the training of the network. For example, a value of 0.05 corresponding to dimensional actually represents a physical value of 50 mm. For tolerance attribute, the scaling factor is unity. For surface finish attribute, the scaling factor is 10. That is, a value of 0.025 for surface finish represents 0.25 microns.

Then output variables for NN1 module consist of process selection and sequence given in output layer. Each node represented each machine operation sequence that which needed and also format as output vector has columns according *machining operation* sequence found in 'THEN' part in thumb rule. *No. of node in output layer = No. of all feasible machining operation* sequence found in 'THEN' part in thumb rule. The typical desired output for NN1 is illustrates in Table (5). The output layer for NN1 consists of 5 neurons to express operation to be machined hole. The column number [1] stands for machine operation drill, column numbers [2] stand for drill-ream, column numbers [3] stand for drill-bore, column numbers [4] stand for drill-bore-grind and column numbers [5] stand for drill-bore-hone.

**Table 5:** The typical desired NN1 output

Column No.	1	2	3	4	5	.....	12
Value	1	0	1	0	0	.....	0

The output layer for NN2 consists of 11 neurons to express tools to be machined hole. The column number [1] stands for cutting tool (T1), column numbers [2] stand for cutting tool (T2), column numbers [3] stand for cutting tool (T3), column numbers [4] stand for cutting tool (T4)...etc. The typical desired output for NN2 is illustrates in Table (6).

**Table 6:** The typical desired NN2 output

Column No.	1	2	3	4	11	.....	26
Value	1	0	1	0	0	.....	0

#### **2.4 Preparation samples**

In NN1 preparation samples using the same set of thumb rules used earlier to pre-structure with neural network. The samples consists of patterns include input vector and output vector. The input pattern of training example representing by the type of feature and its attributes, and the output pattern representing by the machining operation sequences.

The input patterns for the training samples have been chosen randomly in such a way that they cover the entire range of the feature type, diameter, tolerance and surface finish found in part 'IF' of thumb rule. Extract of the training samples for the hole are illustrated in Table (7) and a total of 93 training samples have been developed using the thumb rules. For NN2 the input patterns of the samples are selected from within specified range for each input parameter and representing by the type, condition, dimensional ratio of feature and NN1 outputs.

The output pattern representing by the cutting tools selection and based upon the limitations put on each cutting tool. The basic idea in the selection process is that for each machining feature and the NN1 outputs of machining operations selection combination there is a corresponding cutting tool to be used to generate that feature.

The training patterns used to train the cutting tools selection network for hole are 93 training patterns. Extract of these samples for NN2 are illustrated in Table (8).

#### **2.5 Neural network topology design for modules**

In these modules the proposed topology shown in Figure (2) used Feed forward architecture. It consists of the input layer, the output layer and the hidden layers. The input layer of neurons to represent the input variables, one or more hidden layers of neurons according to complexity of problem and the output layer of neurons to represent output variables consists of one node for each machine operation and cutting tool.

Input layer for NN1 module has 4 inputs that consist of node for type of feature and one node for each feature attributes (dimensional, tolerance and surface finish). The output layer consists of one node for each machine operation for example machine operation and sequences for hole include (drill, drill-ream, drill-bore, drill-bore-grind, and drill-bore-hone) .

The proposed topology for cutting tool selection module consists of connected layers namely; the input layer, the output layer and the hidden layers. The input layer has 4 inputs which are feature type, feature condition, dimension ratio, feature taper and machining operations .

The output layer has neurons each corresponding to a particular cutting tool and has either a value of 0 or 1. If the output neuron value is equal to 1, it is interpreted as meaning that the selection of the cutting tool is supported.

**Table 7:** Training samples of input and output vectors for the machining operations selection

Input vector				Output vector ('1' selected and '0' not selected)											
Feature type	Dimensional	Tolerance	Surface Finish	Drill	Drill - Ream	Drill - Bore	Drill-Bore-Grind	Drill-Bore-Hone	Machining operation sequences for other features						
10	3	0.09	80	1	0	0	0	0	0	0	0	0	0	0	0
10	3	0.011	5	0	1	0	0	0	0	0	0	0	0	0	0
10	3	0.09	20	0	0	1	0	0	0	0	0	0	0	0	0
10	3	0.011	2.5	0	0	0	1	0	0	0	0	0	0	0	0
10	3	0.07	1.25	0	0	0	0	1	0	0	0	0	0	0	0
10	6	0.08	5	1	0	0	0	0	0	0	0	0	0	0	0
10	6	0.008	0.16	0	1	0	0	0	0	0	0	0	0	0	0
10	6	0.015	0.63	0	0	1	0	0	0	0	0	0	0	0	0
10	6	0.006	0.08	0	0	0	1	0	0	0	0	0	0	0	0
10	6	0.004	0.04	0	0	0	0	1	0	0	0	0	0	0	0
10	10	0.21	80	1	0	0	0	0	0	0	0	0	0	0	0
10	10	0.033	5	0	1	0	0	0	0	0	0	0	0	0	0
10	10	0.21	20	0	0	1	0	0	0	0	0	0	0	0	0
10	10	0.033	2.5	0	0	0	1	0	0	0	0	0	0	0	0
10	10	0.015	1.25	0	0	0	0	1	0	0	0	0	0	0	0
10	18	0.13	5	1	0	0	0	0	0	0	0	0	0	0	0
10	18	0.013	0.16	0	1	0	0	0	0	0	0	0	0	0	0
10	18	0.012	0.63	0	0	1	0	0	0	0	0	0	0	0	0
10	18	0.009	0.08	0	0	0	1	0	0	0	0	0	0	0	0
10	18	0.006	0.04	0	0	0	0	1	0	0	0	0	0	0	0
10	30	0.33	80	1	0	0	0	0	0	0	0	0	0	0	0
10	30	0.052	5	0	1	0	0	0	0	0	0	0	0	0	0
10	30	0.33	20	0	0	1	0	0	0	0	0	0	0	0	0
10	30	0.052	2.5	0	0	0	1	0	0	0	0	0	0	0	0
10	30	0.021	1.25	0	0	0	0	1	0	0	0	0	0	0	0



## **2.6 Normalization and Division data**

The normalization will ensure the dataset of all input data of neural network have standard range and wanted to make sure the range is between -1 to 1. For avoiding over-fitting issue, this data was divided in to the dataset of three groups: training set (50%), validation set (25%) and test set (25%) . The training set, which is used for computing the gradient and updating the network weights and biases. Validation set is monitored the error during the training process. The network weights and biases are saved at the minimum of the validation set error. The test set error is not used during training, but it is used only for testing the final solution in order to confirm the actual predictive power of the network .

## **2.7 The Training Process of neural network**

The back-propagation algorithm is using the MATLAB (r2016b) software to simulate ANN operations. The basic idea of the training algorithm is the following: First load in the data: the training samples, the validation samples, and the test samples. Then start to train: run the back propagation algorithm on random samples. After each iteration, see how the network is doing so far (on the validation set), and then decide whether to keep training or not. After stopped, do final evaluations of the network on the test set; this gives an indication of whether the neural net will predict well to samples not originally in the training set . Two ways to train the neural network based on its way to provide the neural network and how to adjust the weights after every single pattern (pattern mode) has been selected or models after all pattern called batch mode .

## **2.8 Testing and Validation of neural network**

On completion of the training of the neural network, the performance of the trained network has been tested on several sets of input feature attributes, which have not been used as part of the training dataset. Validation set is different from test set. Validation set actually can be regarded as a part of training set, because it is used to build your model, neural networks or others . It is usually used for parameter selection and to avoid over fitting. After the neural network has been determined, the result is validation and tested by simulating the output of the neural network with the measured input data. This is compared with the measured outputs. Final validation must be carried out with independent data .

## **2.9 Cutting tools database (standard dimensions)**

Search the cutting tools database to find standard tool dimensions. The search criteria implemented depends on the application of the cutting tool in machining the selected feature. The following are some guidelines used for this purpose .

- (a) Searching for the tool by a key parameter: The search succeeds if the key parameter matches with a field in the data base. This type of search is used for the hole-making tools and form tools (for example, the diameter of drills and the feature code of form grooves) .
- (b) Searching for the tool which has a key parameter greater than or equal to the specified parameter: This type of search is used while matching the cutting edge length .

### 2.10 Case Study

Case study represented by rotational part as shown in Figure (3). The part which has six machining features (hole, external step, groove, face, external taper and external thread). The work implemented using case study for machining operation sequences and cutting tool selection. Input data of the part features for implementation is illustrated in Table (9).

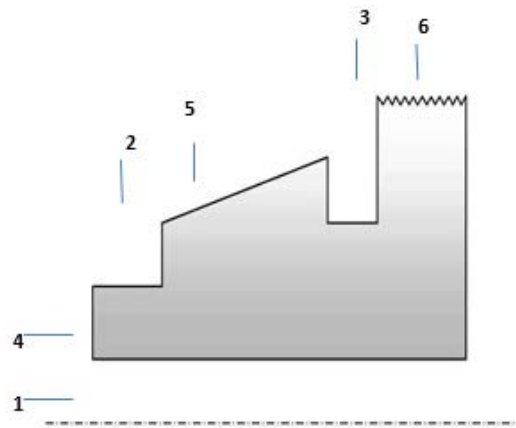
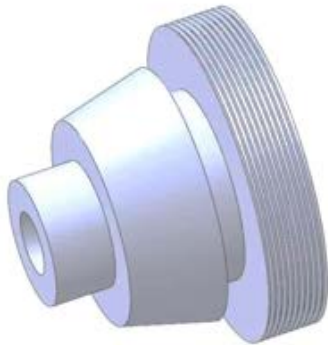

**Figure 3:** 3D CAD module of case study

**Figure 4:** The best model for NN1

**Table 9:** Input data of case study

No.	Feature type	Dimensional ratio (mm)	Tolerance ( $\mu\text{m}$ )	Surface finish ( $\mu\text{m}$ )	Feature condition
	Hole	6	80	0.16	internal
	External step	5	36	6.48	external
	Groove	39.3	205.1	16.47	external
	Face	19.8	161.8	32.93	external
	External taper	22.8	181.5	35.58	external
	External thread	10.8	97.5	18.75	external

In this case study the modules are trained under supervised mode. Where NN1 module has 4 Input Variables and 12 output variables, NN2 module has 4 Input Variables and 26 output variables are divided on three groups: train, valid and test. After many experimental settle down on the best model for NN1 and NN2, the results include performance (MSE) of training, validation, and testing for NN1 shown in Figures (4) and the Regression chart of NN1 for MSE shown in Figure (5). A Figure (6) shows performance (MSE) for NN2 and the

Regression chart of NN2 shown in Figure (7).

Will notice this blue line indicating the training process and the green line indicates the validation process and the pink line indicates the testing process .

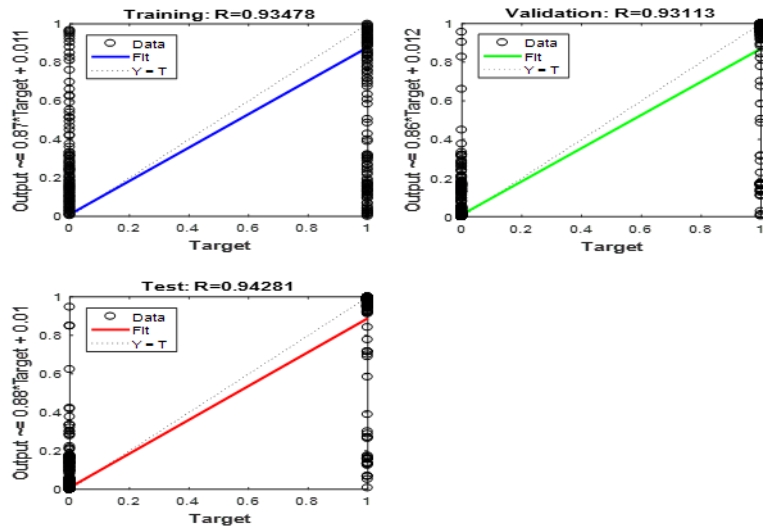

Figure 5: Regression chart of NN1 for MSE

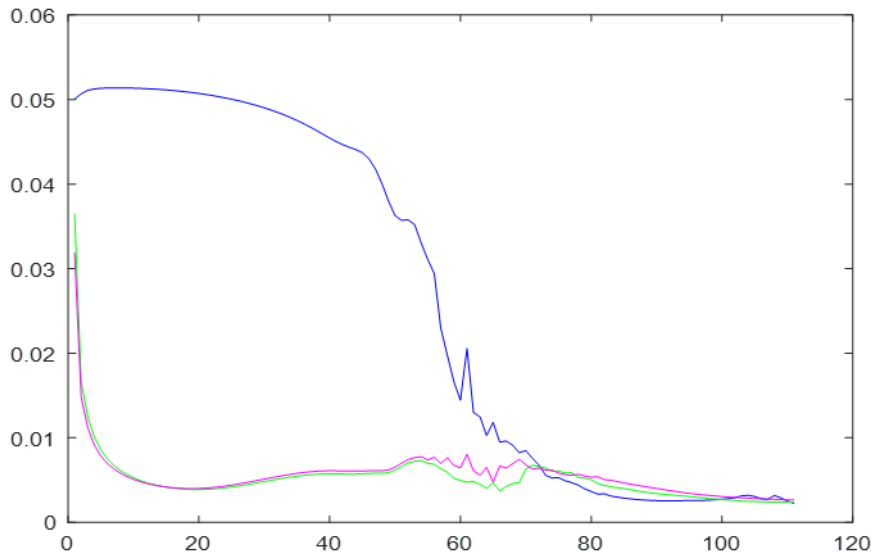
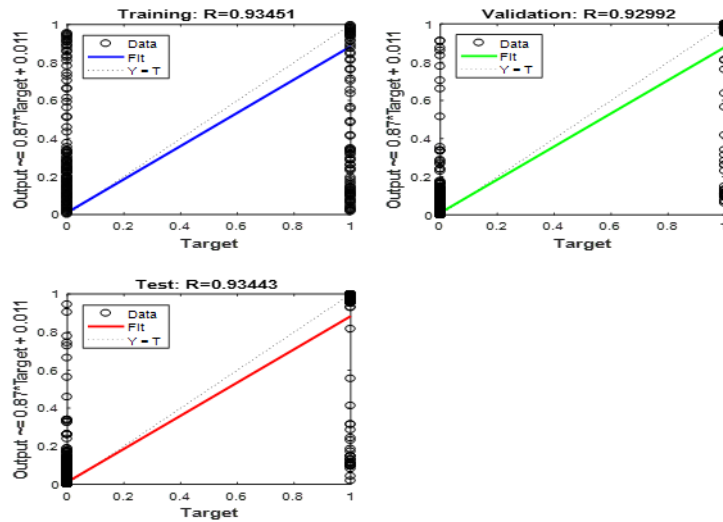
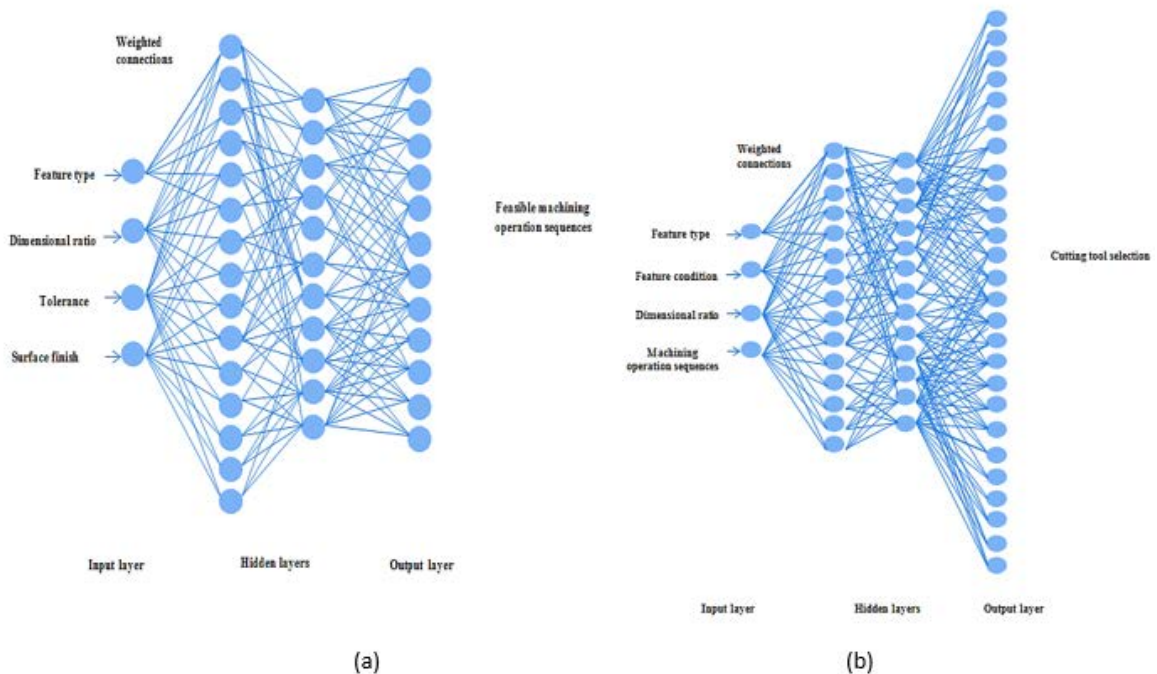

Figure 6: The best model selected for NN2



**Figure 7:** Regression chart of NN2 for MSE

It is clear that the training process stabilizes after about 254 epochs of NN1 and about 111 of NN2 for the training data presented in this work. The results obtained after training, validation and testing the data under different parameter, MSE gives better results. The best selected topologies of two modules are shown in Figure (8) and the result of best selected parameters for modules illustrated in Table (10).



**Figure 8:** The best topology (a) NN1module (b) NN2 module



**Table 10:** The result of best selected parameters for modules

Parameters	Number and type of modules	
	NN1 module	NN2 module
Type of model	Multilayer perceptron network	Multilayer perceptron network
Number of layers	4(two hidden layer)	4(two hidden layer)
Inputs	4	4
Outputs	12	26
Hidden layers	2	2
Neurons in the hidden layer	15-11	15-13
Activation function of hidden layer	logistic	logistic
Activation function of output layer	Linear (purelin)	linear(purelin)
Epoch	500	111
Stopped at epoch	254	111
Error target value	0.001	0.001
Learning rate	0.4	0.7
Performance( MSE) of training	0.0081	0.0650
Performance(MSE)of validation	0.0080	0.0647
Performance( MSE) of testing	0.0078	0.0695
Data sample division on	50%-25%-25%	50%-25%-25%
Type of analysis	regression	regression

**Table 11:** Process plan sheet

No.	Feature of part	Machining operation sequences	Cutting tools selection
1.	Hole	Drill- ream	T2-T6
2.	External step	Turn	T12
3.	Groove	Grooving	T19
4.	Face	Facing	T20
5.	External taper	Turn- Grind	T22-T24
6.	External thread	Threading	T26

The result shows that the value predicted using neural network predict closely to the goal (target) can be accepted as a successive method. So the measures of efficiency obtained with the different models, by using number of experiments have been done to select best model and to evaluate the individual effects of training parameters on the performance of neural network. The final results of case study which are selected the best solution according to produce six sequences of machining operation and eight cutting tools. Case study is improved based on integration state between process planning and neural network toward to solution the problem of process planning. The results are defined and represented as a process plan sheet contains the required outputs according to the sequence of operations. Process plan sheet is illustrated in Table (11).

### **3. Conclusion**

In this paper, automating process planning by used ANN. The neural networks can provide the suitable machining operations sequences and cutting tools in order to machine the shape of rotational parts by learning from the neuron networks patterns. In addition, ANN applied back propagation algorithm this method worked to reduce local minimum error, the time for developing all system of process planning, and improving quality of training and response of NN. The computed MSE values indicated the performance is acceptable by learning curve in NN1 shows the MSE of 0.0081 and NN2 shows the MSE of 0.0650 which is feasible and applicable in selection of machining operation sequences and cutting tool. The computed values of regression near 1 that means machines learned 100%. The results obtained have demonstrated the applicability of ANN for these tasks of process planning. Finally this application has shown a good success in knowledge acquisition and fast inference compared with the traditional approaches of automated process planning. After result analyses and the example part was tested successfully, have found that the proposed model is able to give best prediction solutions for process planning problem of machining operations sequences in CAPP systems.

### **Acknowledgements**

This Project was supported by University of Technology and Department of Production Engineering and Metallurgy.

### **References**

- [1] S. Butdee, C. Noomtong, and S. Tichkiewitch, "A process planning system with feature based neural network search strategy for aluminum extrusion die manufacturing," arXiv preprint arXiv:0907.0611, 2009.
- [2] S. Deb, K. Ghosh, and S. Paul, "A neural network based methodology for machining operations selection in computer-aided process planning for rotationally symmetrical parts," *Journal of Intelligent Manufacturing*, vol. 17, pp. 557-569, 2006.
- [3] I. Rojek, "Technological process planning by the use of neural networks," *AI EDAM*, vol. 31, pp. 1-15, 2017.

- [4] N. Ahmad and A. Haque, "Artificial Neural Networks Based process selection for cylindrical surface machining," in Proceedings of the Int. Conf. on Manufacturing, pp. 09-11, 2002.
- [5] I. Basheer and M. Hajmeer, "Artificial neural networks: fundamentals, computing, design, and application," *Journal of microbiological methods*, vol. 43, pp. 3-31, 2000.
- [6] M. Santochi and G. Dini, "Use of neural networks in automated selection of technological parameters of cutting tools," *Computer Integrated Manufacturing Systems*, vol. 9, pp. 137-148, 1996.
- [7] R. BenKhalifa, N. B. Yahia, and A. Zghal, "Integrated neural networks approach in CAD/CAM environment for automated machine tools selection," *Journal of Mechanical Engineering Research*, vol. 2, pp. 25-38, 2010.
- [8] C. R. Devireddy, "Feature-based modelling and neural networks-based CAPP for integrated manufacturing," *International Journal of Computer Integrated Manufacturing*, vol. 12, pp. 61-74, 1999.
- [9] S. Deb, J. R. Parra-Castillo, and K. Ghosh, "An integrated and intelligent computer-aided process planning methodology for machined rotationally symmetrical parts," *International Journal of Advanced Manufacturing Systems*, vol. 13, pp. 1-26, 2011.
- [10] S. M. Amaitik and S. E. Kiliç, "An intelligent process planning system for prismatic parts using STEP features," *The International Journal of Advanced Manufacturing Technology*, vol. 31, pp. 978-993, 2007.
- [11] A. S. Rana, R. Kumar, M. Singh, and A. Kumar, "Operation sequencing in CAPP by using artificial neural network," *International Journal of Innovative Research in Science, Engineering and Technology*, vol. 2, pp. 1137-1141, 2013.
- [12] S. COROMANT, "Torneado General," ed: SANDVIK COROMANT, 2009.
- [13] S. Coromant, "Deep Hole Drilling: Product Catalogue and Application Guide," Sandvik Coromant, 2007.
- [14] G. Halevi and R. Weill, *Principles of process planning: a logical approach*: Springer Science & Business Media, 2012.
- [15] J. G. Bralia, "Handbook of product design for manufacturing: a practical guide to low-cost production," McGraw-Hill Book Company, 1986, p. 1120, 1986.