



---

## **Nonlinear Optical Properties of Polythiophene and Iodine Doped Thin Films by Aerosol Assisted Plasma Jet Polymerization at Atmospheric Pressure**

Hammad R. Humud<sup>a\*</sup>, Manal Midhat Abdullah<sup>b</sup>, Dawood Majed Khudhair<sup>c</sup>

<sup>a,b,c</sup>Baghdad university. college of science, Physics dept., Iraq

<sup>a</sup>Email: Dr.hammad6000@ahoo.com

<sup>b</sup>Email: manal.madhat@yahoo.com

<sup>c</sup>Email: dawoodmajed@gmail.com

### **Abstract**

In this work, the nonlinear optical properties of pure Polythiophene and in situ iodine doping Polythiophene thin films on glass substrate, prepared by aerosol assisted plasma jet polymerization at atmospheric pressure, thin films were studied through open and closed Z-scan technique under laser excitation at 532 nm, CW solid state laser with an output power of 100 mW. The nonlinear optical properties of pure Polythiophene thin films prepped at different gas flow rate and Polythiophene thin films iodine doped at constant gas flow rate 1lm-1 and different iodine weight concentration 1, 3, 5, and 7% were studied. the closed aperture Z-scan data indicates that the sign of the refraction nonlinearity is negative for thin films prepared at gas flow rate 1lm-1, 2lm-1  $n_2$   $0.938 \times 10^{-5}$  and  $1.247 \times 10^{-5}$  cm<sup>2</sup>/mW .and positive nonlinearity for thin films prepared at other gas flow rate,  $n_2$   $1.409 \times 10^{-5}$  and  $1.547 \times 10^{-5}$  cm<sup>2</sup>/mW for gas flow rate 3 and 4 lm-1 respectively. And the open Z-scan measurements show two photon absorption  $\beta$  cm/mW, 2.797cm/mW for gas flow rate 4lm-1 show saturated absorption  $\beta$  cm/mW, 0.993, 1.25 and 0.3 cm/mW for all gas flow rate 1, 2 and 3 lm-1 respectively. For Polythiophene thin films iodine doped at constant gas flow rate the closed aperture Z-scan measurements shows positive nonlinearity for thin films prepared at iodine concentration 1,3 and 7%  $n_2$   $2.510 \times 10^{-5}$ ,  $2.101 \times 10^{-5}$  and  $1.638 \times 10^{-5}$  cm<sup>2</sup>/mW respectively.

---

\* Corresponding author.

While thin films prepared with iodine concentration 5% shows negative nonlinearity  $n_2$   $2.343 \times 10^{-5}$  cm<sup>2</sup>/mW respectively. The open aperture Z-scan measurements for Polythiophene thin films doped with iodine by different concentration 1, 3, 5, and 7% and constant gas flow rate show saturated absorption  $\beta$  cm/mW, 2.140 and 2.001 cm/mW at iodine concentration 5 and 7% for all for all gas flow rate show two photon absorption  $\beta$  cm/mW, 1.763 and 2.037 cm/mW. It can be concluding that, the possibility of obtaining direct and inexpensive method to prepare saturated absorption thin films material, by aerosol assisted plasma jet polymerization at atmospheric pressure.

**Keywords:** Polythiophene iodine; doping; thin films; nonlinear optical properties.

## 1. Introduction

Reliable methods for determining the nonlinear optical properties of materials (i.e. nonlinear absorption and nonlinear refraction) have been developed for wide ranging applications such as methods, “z-scan”, developed by Eric Van Storyland [1, 4] remains the standard technique. The z-scan technique is performed by translating a sample through the beam waist of a focused beam and then measuring the power transmitted through the sample. Z-scan has many possible configurations (e.g. “EZ-Scan [5], “White Light z-scan [6], and “Excite-Probe z-scan [7] In this note, only the standard “open aperture” and “closed aperture” z-scan will be discussed. The two measurable quantities connected with the z-scan are nonlinear absorption (NLA) and nonlinear refraction (NLR). These parameters are associated with the imaginary and real part of the third order nonlinear susceptibility,

the paper provide important information

note is to describe a simple implementation of the z-scan technique that can be used to characterize relatively thin (< 5mm) optical materials.

## Experimental

Iodine-doped Polythiophene thin films have been prepared by aerosol assisted plasma polymerization. Thin films were prepared by dielectric barrier discharge plasma jet a homemade [8]. The thin films were deposited on glass substrates. Pure thiophene monomer was used as the organic precursor. Figure (1) schematic diagram for the non-equilibrium atmospheric pressure plasma Iodine-doped Polythiophene thin films preparation. Argon gas with flow rate of 1 L/min passes through the nebulizer which contains a mixture of iodine and thiophene with weight mixing ratios of 1%, 3%, 5% and 7%. The mixture convert to aerosol, this aerosol was guided by the Ar gas to the plasma jet. The plasma was ignited by using an electric source at a fixed frequency of 28.0 kHz. The plasma was generated downstream to the substrate which was positioned suitable distance from the

### 1- Closed-aperture z-scan

A closed-aperture Z-Scan measures the change in intensity of a beam, focused by lens L in Figure (2), as the sample passes through the focal plane. Photo-detector PD collects the light that passes through an axially centered aperture A in the far field. The change in on-axis intensity is caused by self-focusing or self-defocusing by the sample S as it travels through the beam waist. A TEM<sub>00</sub> Gaussian beam has greatest intensity at the center and will create a change in index of refraction forming a lens in a nonlinear sample as shown in Figure. (2), [9].

To show how the Z-scan transmittance as a function of Z is related to the nonlinear refraction of the sample, if a medium with a negative nonlinear refraction index and a thickness smaller than the diffraction length of the focused beam. This can be considered as a thin lens of variable focal length. Beginning far from the focus ( $Z < 0$ ), the beam irradiance is low and nonlinear refraction is negligible.

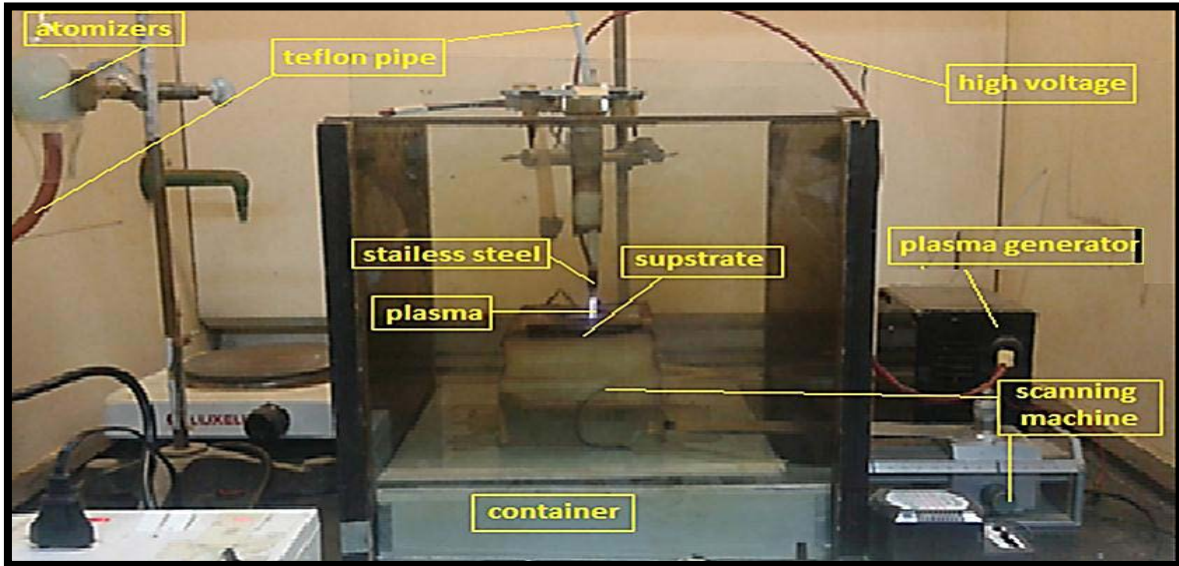

**Figure 1:** Schematic diagram for the non-equilibrium atmospheric pressure plasma Iodine-doped Polythiophene thin films preparation experimental set-up

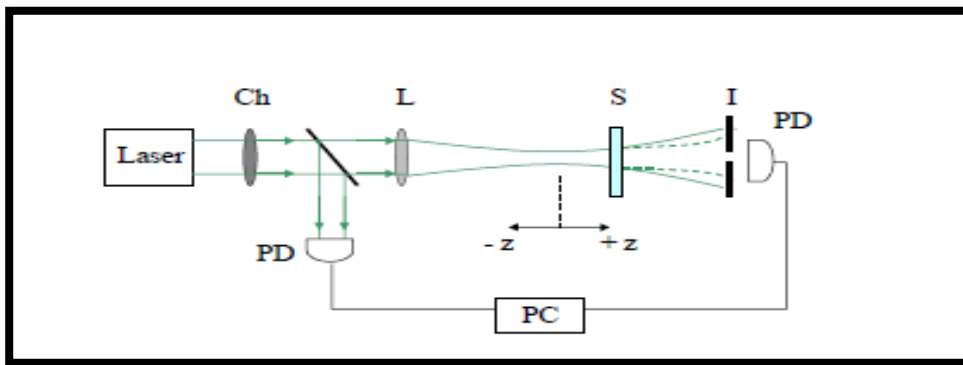

**Figure 2:** Closed-aperture Z-Scan [10].

In this condition, the measured transmittance remains constant (i.e., Z-independent). As the sample was approaches the beam focus, irradiance increases, leading to self-lensing in the sample. A negative self-lens before the focal plane will tend to collimate the beam on the aperture in the far field, increasing the transmittance measured at the iris position. After the focal plane, the same self-defocusing was increases the beam divergence, leading to a widening of the beam at the aperture and thus reducing the measured transmittance. Far from focus ( $Z > 0$ ), again the nonlinear refraction is low resulting in a transmittance Z-

independent. A pre-focal transmittance maximum (peak), followed by a post-focal transmittance minimum (valley) is a Z-scan signature of a negative nonlinearity. An inverse Z-scan curve (i.e., a valley followed by a peak) characterize is a positive nonlinearity. Figure (3) depicts these two situations [11].

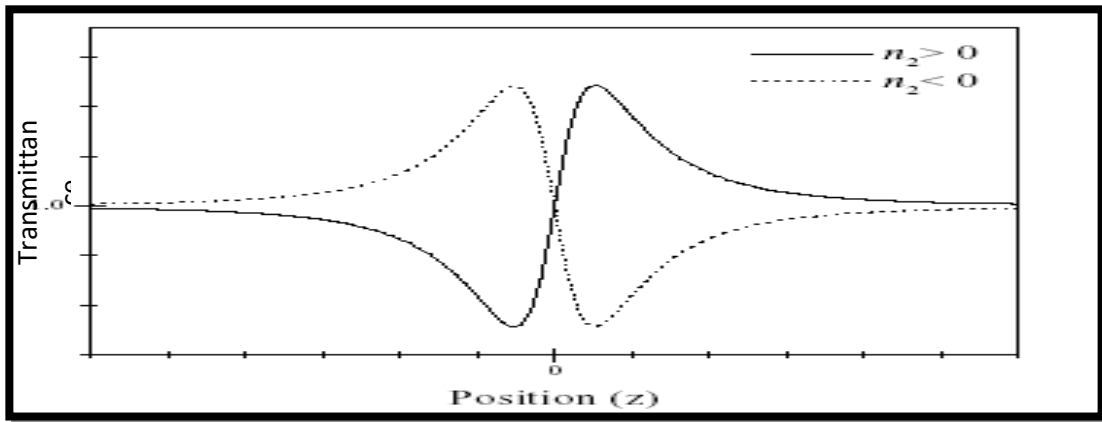

**Figure 3:** Calculated Z-scan transmittance curves for a cubic Nonlinearity.

The relative on-axis transmittance of the sample measured (at the small aperture of the far-field detector) is given by [12].

$$T_{(z, \Delta\Phi_0)} = 1 - \frac{4\Delta\Phi_0 \frac{Z}{Z_0}}{\left\{ \left( \frac{Z^2}{Z_0^2} \right) + 9 \right\} \times \left\{ \left( \frac{Z^2}{Z_0^2} \right) + 1 \right\}} \quad (1)$$

Where T is the transmittance through the aperture, which is a function of the sample position Z, the nonlinear refractive index is calculated from the peak to valley difference of the normalized transmittance by the following formula Sheik-Bahae. [12].

$$n_2 = \Delta\Phi_0 / I_0 L_{eff} k \quad (2)$$

Where,  $\Delta\Phi_0$ : - nonlinear phase shift,  $k = 2\pi / \lambda$ ,  $\lambda$ , is the wavelength of the beam.  $L_{eff}$ : - the effective length of the sample, can be determined from the following formula Sheik-Bahae. [12].

$$L_{eff} = \frac{(1 - e^{-\alpha_0 L})}{\alpha_0} \quad (3)$$

Where, L: - the sample length,  $\alpha_0$  :- linear absorption coefficient, In equation (4),  $I_0$  is the intensity at the focal spot given by Ready.J.F. (1978), [13].

$$I_0 = \frac{2P_{peak}}{\pi\omega_0} \tag{4}$$

Where,  $\omega_0$ : the beam radius at the focal point,  $P_{peak}$ : the peak power.

## 2. Open aperture z-scan technique

An open-aperture z-scan measures the change in intensity of a beam, focused by lens L as in Figure (4), in the far field at detector D, which captures the entire beam. In open aperture z-scan the aperture is removed and the transmittance is no longer sensitive to the beam distortion and z-scan data is a function of nonlinear absorption [14].

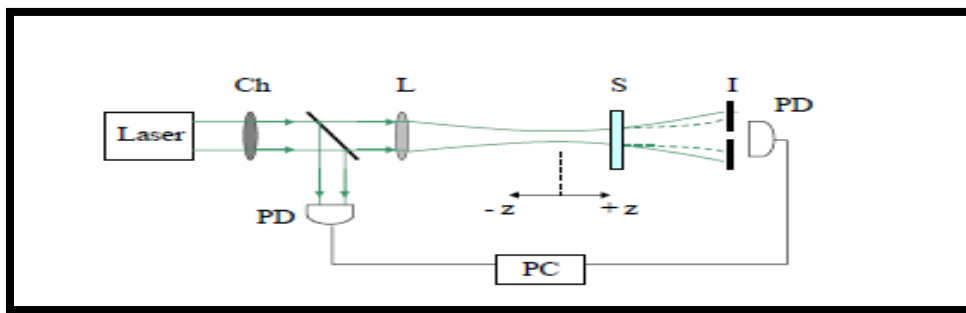

Figure 4: Open-aperture Z-Scan

The change in intensity is caused by multi-photon absorption in The Sample S as it travels through the beam waist. In the focal plane where the intensity is greatest, the largest nonlinear absorption is observed. At the "tails" of the z-scan signature, where  $|z| \gg z_0$ , the beam intensity is too weak to elicit nonlinear effects as show in figure. (5) .

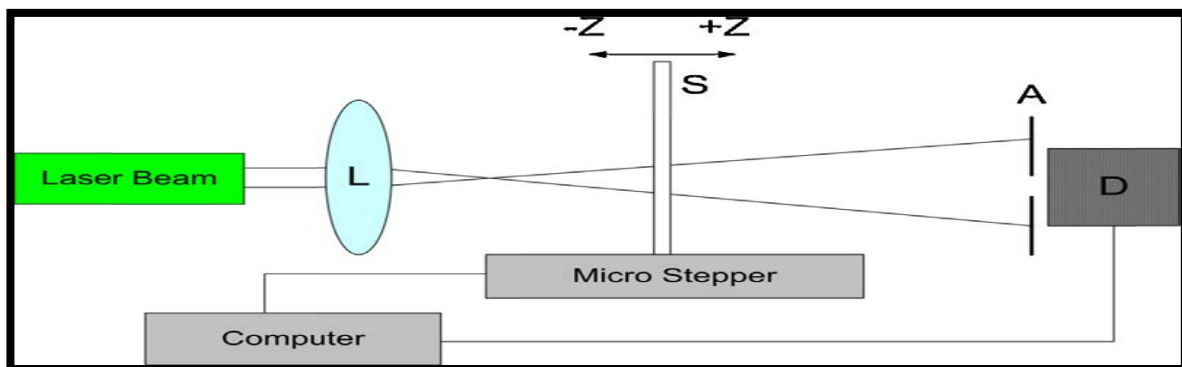
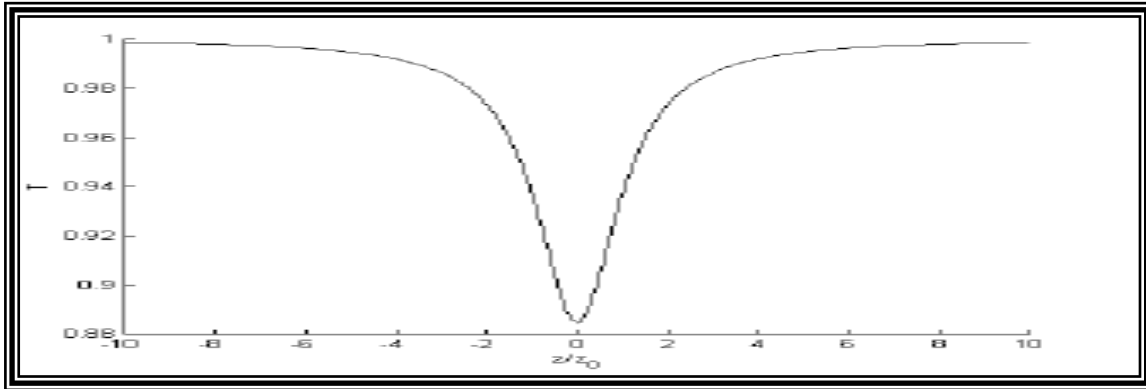

Figure 5: Open-aperture Z-scan setup. The laser beam, focused by lens L, is entirely collected at detector D

Figure. (6) Shows the relative transmittance change recorded by the open-aperture detector. For a sample exhibiting two-photon absorption. A symmetric valley is the hallmark of a positive nonlinear absorption coefficient  $\beta$ .

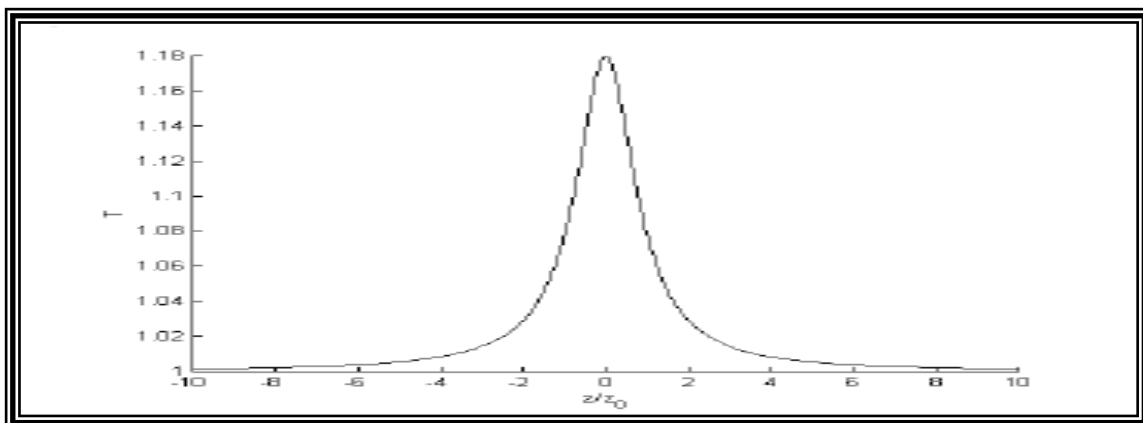

**Figure 6:** Simulated open-aperture Z-scan signature for a sample with positive nonlinear absorption coefficient

The nonlinear absorption coefficient for pure two-photon absorption is calculated as shown in equation (6)

$$T(Z) = \sum_{m=0}^{\infty} \frac{\left[ \frac{\beta I_0 L_{eff}}{1 + (Z/Z_0)^2} \right]^m}{(m+1)^{3/2}} \quad (5)$$

Where  $Z$ : - is the sample position at the minimum transmittance,  $m$ : - integer ( $z$ ):- the minimum transmittance. The two terms in the summation are generally sufficient to determine  $\beta$ . Figure (7) shows the relative transmittance change recorded by the open-aperture detector, for a sample exhibiting absorption saturation. A symmetric peak is the hallmark of a negative nonlinear absorption coefficient  $\beta$ , indicating absorption saturation.

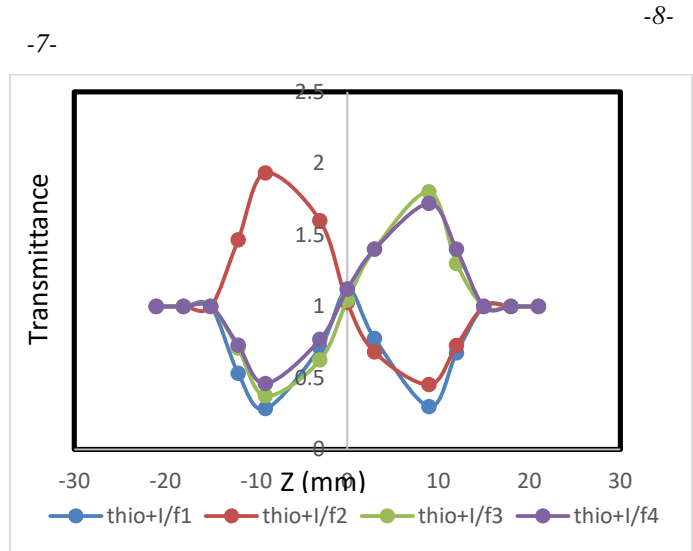
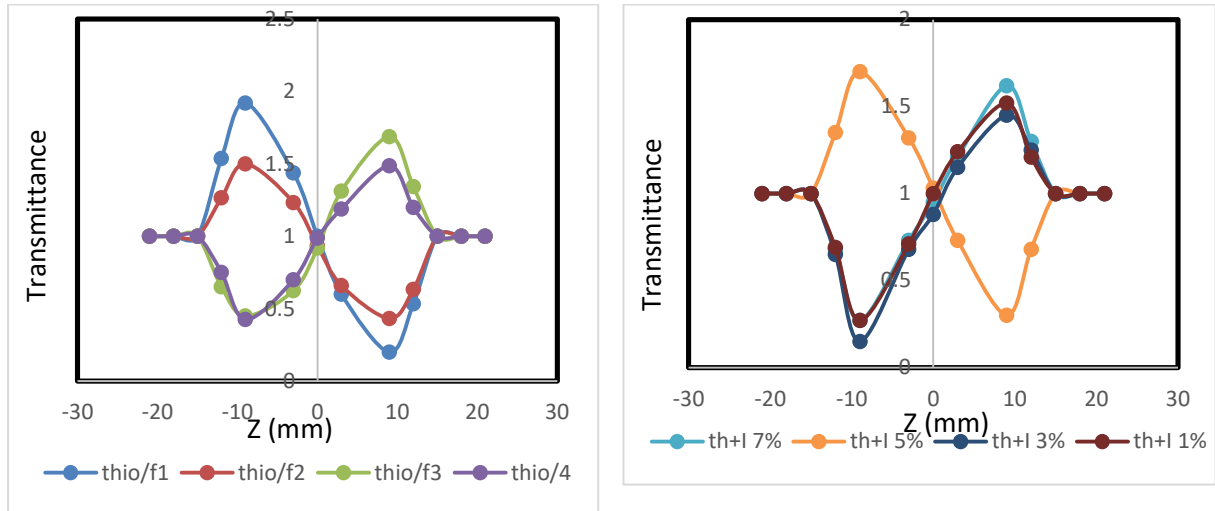

**Figure 7:** Simulated open-aperture z-scan signature for a sample with saturation absorption

### 3. Results and discussion

The nonlinear refractive index of three cases pure Polythiophene at different gas flow rate, iodine doped Polythiophene at different gas flow rate uncontrolled doping, Polythiophene controlled iodine doped at constant gas flow rate were studied. All these three cases were measured by the z-scan technique. Figure (8) shows a closed-aperture z-scan for the first case, pure Polythiophene at different gas flow rate. In Figure (8), the nonlinear effect region is extended from -1.5 cm to 1.5 cm and transmittance difference between peak and valley,  $\Delta p-v$  at flow rate (1, 2, 3, and 4)  $\text{lm}^{-1}$  equals to (0.25, 0.32, 0.36, and 0.36) respectively. The peak followed by a valley transmittance curve obtained from the closed aperture Z-scan data indicates that the sign of the refraction nonlinearity is negative, (i.e. self-defocusing) for thin films prepared at gas flow rate 1 and 2  $\text{lm}^{-1}$ . and positive nonlinearity for thin films prepared at 3, 4  $\text{lm}^{-1}$  gas flow rate. For the second case iodine doped Polythiophene at different gas flow rate uncontrolled doping the closed aperture measurements were shown in Figure (9) at wavelength 532nm. In Figure (9), the nonlinear effect region is extended from -1.5 cm to 1.5 cm and transmittance difference between peak and valley,  $\Delta p-v$  at flow rate (2, 3, and 4)  $\text{lm}^{-1}$  equals to (0.19, 0.19 and 0.31) respectively. The peak followed by a valley transmittance curve obtained from the closed aperture Z-scan data indicates that the sign of the refraction nonlinearity is negative, for thin films prepared at gas at flow rate 2  $\text{lm}^{-1}$ . and positive nonlinearity for thin films prepared at 3 and 4  $\text{lm}^{-1}$  gas flow rate. At the third case Polythiophene controlled iodine doped at constant gas flow rate. Polythiophene thin films doped with iodine by different concentration (1, 3, 5, and 7%) the closed aperture measurements were done at wavelength 532 nm. These measurements were shown in Figure (10) In this Figure, the nonlinear region is between -1.5 cm to 1.5 cm and  $\Delta p-v$  at iodine concentrations (1, 3, 5, 7%) equals (0.58, 0.49, 0.52 and 0.5) respectively. Figure (4.76) shows positive nonlinearity for thin films prepared at iodine doping concentration 1, 3 and 7%. While thin films prepared with iodine doping concentration 5% shows negative nonlinearity. From the figures note that the iodine doping and the gas flow rate change the behavior of thin films this shows that gas flow rate alters the thin films combination and the iodine atoms linked into the polymer and become part of its combination. From figure (10) it can see that transmittance difference between peaks and valleys,  $\Delta p-v$  for Polythiophene thin films prepared by plasma jet large thane that for polyaniline thin films. This indicated that Polythiophene thin films strongly influenced by the laser power. In order to investigate the nonlinear absorption coefficient at the 532 nm wavelength for the first case, pure Polythiophene at different gas flow rate (1, 2, 3, and 4)  $\text{lm}^{-1}$  were done as in Figure (11). Figure (11), represent the open aperture for pure Polythiophene thin films at different gas flow rate the behavior of transmittance started linearly at different distances from the far field of the sample position (-Z). Transmittance curve for thin films prepared at gas flow rate 4  $\text{lm}^{-1}$  begins to decrease until it reaches the minimum value ( $T_{\min}$ ) at the focal point, where  $Z=0$  mm. The transmittance begins to increase toward the linear behavior at the far field of the sample position (+Z). The change of the intensity in this case is caused by two photon absorption when the sample travels through the beam waist. For thin films prepared at gas flow rate (1, 2, and 3)  $\text{lm}^{-1}$  the behavior of transmittance started linearly at different distances from the far field of the sample position (-Z). At the near field the transmittance curve begins to increase until it reaches the maximum value ( $T_{\max}$ ) at the focal point, where  $Z=0$  mm. The transmittance begins to decrease toward the linear behavior at the far field of the sample position (+Z). This behavior of nonlinear optical absorption response is demonstrated by saturated absorption. For the second case, iodine doped Polythiophene at different gas flow rate

uncontrolled, iodine doping the open aperture measurements were shown in Figure (12) at wavelength 532nm.



-9-

**Figure 8:** Closed aperture Z-scan with CW laser at 532 nm of different 8-gas flow rate 9- concentration iodine doping Polythiophene.10-iodine doping uncontrolled.

Figure (12), represent the open aperture for iodine doped Polythiophene at different gas flow rate uncontrolled iodine doping, the behavior of transmittance started linearly at different distances from the far field of the sample position (-Z). Transmittance curve for thin films prepared at gas flow rate  $1\text{lm}^{-1}$  and iodine doped begins to decrease until it reaches the minimum value ( $T_{\text{min}}$ ) at the focal point, where  $Z=0$  mm. The transmittance begins to increase toward the linear behavior at the far field of the sample position (+Z). The change of the intensity in this case is caused by two photon absorption where the sample travels through beam waist. For thin films prepared at gas flow rate (2, 3 and 4)  $\text{lm}^{-1}$  and iodine doped the behavior of transmittance started linearly at different distances from the far field of the thin films position (-Z). At the near field the transmittance curve begins to increase until it reaches the maximum value ( $T_{\text{max}}$ ) at the focal point, where  $Z=0$  mm. The transmittance begins to decrease toward the linear behavior at the far field of the sample position (+Z). This



behavior of nonlinear optical absorption response is demonstrated by saturated absorption. The third case Polythiophene controlled iodine doped at constant gas flow rate. Polythiophene thin films doped with iodine by different concentration (1, 3, 5, and 7%) the open aperture measurements were done at wavelength 532 nm. These measurements were shown in Figure (13). The behavior of transmittance started linearly at different distances from the far field of the sample position (-Z). Transmittance curve for thin films prepared at iodine concentration (1 and 7) and constant gas flow begins to decrease until it reaches the minimum value (Tmin) at the focal point, where Z=0 mm. The transmittance begins to increase toward the linear behavior at the far field of the sample position (+Z). The change of the intensity in this case is caused by two photon absorption where the sample travels through beam waist. For thin films prepared at iodine concentration (3 and 5) the behavior of transmittance started linearly at different distances from the far field of the thin films position (-Z). At the near field the transmittance curve begins to increase until it reaches the maximum value (Tmax) at the focal point, where Z=0 mm. The transmittance begins to decrease toward the linear behavior at the far field of the sample position (+Z). This behavior of nonlinear optical absorption response is demonstrated by saturated absorption.

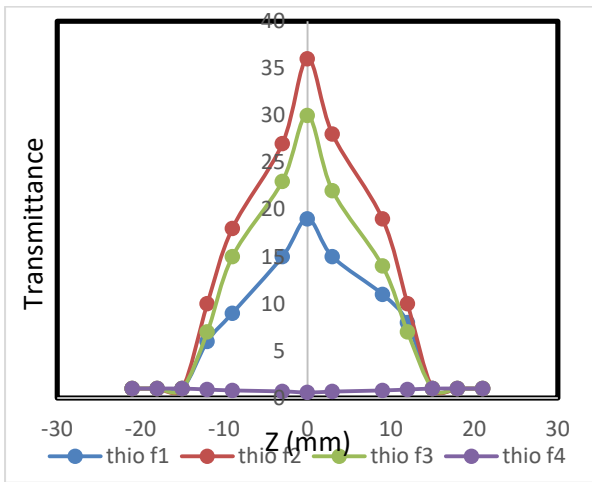

-11-

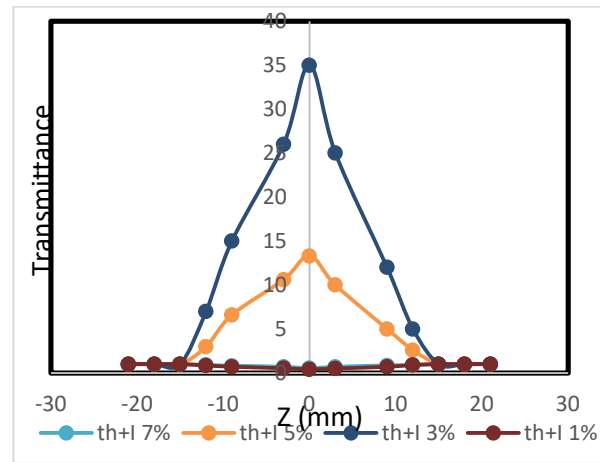

-12-

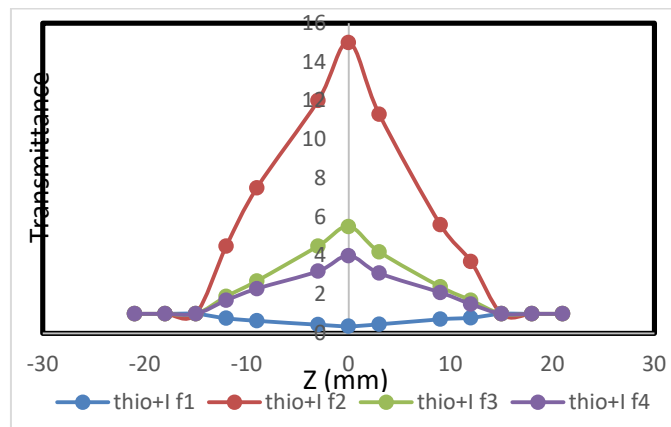

-13-

**Figure 9:** Open Aperture Z-Scan for polyaniline thin films different 11-gas flow rate 12- concentration iodine doping 13- iodine doping uncontrolled. Polythiophene using CW laser at 532 nm.

**Table:** The nonlinear optical properties for pure Polythiophene, iodine doping Polythiophene thin films at 532 nm.

<b>pure Polythiophene thin films</b>	<b><math>\alpha</math> cm<sup>-1</sup></b>	<b><math>n_o</math></b>	<b><math>L_{eff}</math> Cm</b>	<b><math>\Delta T_{pv}</math></b>	<b><math>\Delta\Phi_0</math></b>	<b><math>n_2</math> cm<sup>2</sup>/mw</b>	<b>T(z)</b>	<b><math>\beta</math> cm/mw</b>
gas flow 1	4786	1.25	1.540×10 <sup>-5</sup>	0.25	0.6158	0.938×10 <sup>-5</sup>	0.195	0.993
gas flow 2	4964	1.25	1.483×10 <sup>-5</sup>	0.32	0.7882	1.247×10 <sup>-5</sup>	0.25	1.321
gas flow 3	5516	1.26	1.476×10 <sup>-5</sup>	0.36	0.8867	1.409×10 <sup>-5</sup>	0.3	1.593
gas flow 4	5796	1.26	1.345×10 <sup>-5</sup>	0.36	0.8867	1.547×10 <sup>-5</sup>	0.48	2.797
<b>Polythiophene thin films uncontrolled iodine doping</b>	<b><math>\alpha</math> cm<sup>-1</sup></b>	<b><math>n_o</math></b>	<b><math>L_{eff}</math> Cm</b>	<b><math>\Delta T_{pv}</math></b>	<b><math>\Delta\Phi_0</math></b>	<b><math>n_2</math> cm<sup>2</sup>/mw</b>	<b>T(z)</b>	<b><math>\beta</math> cm/mw</b>
gas flow 2	10372	1.71	1.975×10 <sup>-5</sup>	0.19	0.4680	0.556×10 <sup>-5</sup>	0.14	0.555
gas flow 3	11461	1.71	1.787×10 <sup>-5</sup>	0.19	0.4680	0.614×10 <sup>-5</sup>	0.38	1.667
gas flow 4	11223	1.55	1.397×10 <sup>-5</sup>	0.31	0.7636	1.282×10 <sup>-5</sup>	0.44	2.469
<b>Polythiophene thin films controlled iodine doping</b>	<b><math>\alpha</math> cm<sup>-1</sup></b>	<b><math>n_o</math></b>	<b><math>L_{eff}</math> Cm</b>	<b><math>\Delta T_{pv}</math></b>	<b><math>\Delta\Phi_0</math></b>	<b><math>n_2</math> cm<sup>2</sup>/mw</b>	<b>T(z)</b>	<b><math>\beta</math> cm/mw</b>
PTh 1%	11496	1.53	1.334×10 <sup>-5</sup>	0.58	1.4286	2.510×10 <sup>-5</sup>	0.3	1.763
PTh 3%	1022	1.48	1.349×10 <sup>-5</sup>	0.49	1.2069	2.101×10 <sup>-5</sup>	0.35	2.037
PTh 5%	17293	1.78	1.282×10 <sup>-5</sup>	0.52	1.2808	2.343×10 <sup>-5</sup>	0.4	2.140
PTh 7%	5199	1.32	1.763×10 <sup>-5</sup>	0.5	1.2315	1.638×10 <sup>-5</sup>	0.45	2.001

#### **4. Conclusion**

The transmission characteristics of plasma polymerized thiophene in its pristine and iodine doped forms are studied using Z-Scan technique. The samples show a saturable absorption behavior and the iodine doping effect the transmittance curve of the material. Z-Scan studies at different intensities and frequency range is needed to substantiate use of these materials as optical limiting and sensor eye protection like applications

#### **References**

- [1]. Van Stryland, E.W., Vanherzeele, H., Woodall, M.A., Soileau, M.J., Smirl, A.L., Guha, S. and Bogess, T.F., *Opt. Eng.*, 24, 613 (1985).
- [2]. Mendonca, C.R., Correa, D.S., Baldacchini, T., Tayalia, P., and Mazur, E., submitted to *J. Appl. Phys.*
- [3]. Mizrahi, M., DeLong, K., Stegeman, G., Saifi, M. and Andrejco, M., *Appl. Phys. Lett.*, 55, 1823 (1989).
- [4]. Sheik-Bahae, M., Said, A.A., Wei, T., Hagan, D.J., Van Stryland, E.W., *IEEE. J. Quantum Electron.*, 26, 760 (1990)
- [5]. Xia, T., Sheik-Bahae, M., Said, A. A., Hagan, D.J., Van Stryland, E.W., *Int. J. Nonlinear Opt. Phys.*, 3, 489 (1994).
- [6]. Balu, M., Hales, J., Hagan, D.J., Van Stryland, E.W., *Opt. Express*, 12, 3820 (2004).
- [7]. Imangholi B, Hasselbeck M.P., Sheik-Bahae M., *Opt. Commun.*, 227, 337, (2003).
- [8]. Hammad R. Humud, Thikra Kh. Obayes and Qusay A. Abbas *International Journal of Current Engineering and Technology*, 4, 2580(2014)
- [9]. R. de Nalda, R. del Coso, J. Requejo-Isidro, J. Olivares, A. Suarez-Garcia, J. Solis and C. N. Afonso, *Nalda et al. Vol, 19, No. 2, (2002).*
- [10]. S.L. G´omez, F.L.S. Cuppo, and A.M. Figueiredo Neto, *Brazilian Journal of Physics*, Vol.33, No. 4, (2003).
- [11]. C.S. Winter, R.J. Manning, S.N. Oliver and C.A.S Hill, *Optics Communications*, Vol. 90, (1992), p.139.
- [12]. M. Sheik-Bahae, A. A. Said, T. Wel, D. J. Hagan and E. W. Van, *IEEE Journal of Quantum Electronic*, Vol 26, NO. 4.(1990),p 760.
- [13]. J.F. Ready, "Industrial Application of Lasers", 2<sup>nd</sup>, Academic Press, San Diego, (1978).
- [14]. M.Sheik, A. Ali, J.David "Sensitive Measurement of Optical Nonlinearities Using aSingle Beam" *IEEE Journal of Quantum electronics* Vol, 26 No 4. (1990), p 760.