



Real Time Monitoring of Environmental Parameters (RT-MEP)

Ali Ikram ^{a*}, Muhammad Mustafa ^b, Asad Khaliq ^c, Muhammad Daniyal Bakht ^d

^{a,b,c,d} Faculty of Electrical Engineering GIK Institute of Engineering Sciences and Technology, KPK, Pakistan

^a Email: aly.ikram1@gmail.com

^b Email: mustafagiki@gmail.com

^c Email: asadmali@giki.edu.pk

^d Email: daniyalbg@hotmail.com

Abstract

The fluctuations in parameter pertaining to environment such as temperature, soil movement, light intensity etc. can directly or indirectly influence mankind and their activities. This paper focuses on designing a new workbench that takes into account hardware as well as software aspects in monitoring and assessment of environmental anomalies. The idea is aimed to create an advanced, low cost and user friendly interface. Realization is being done by the orientation and placement of contemporary selection of sensors aimed to record and alert any perturbations in parameters such as soil moisture, atmospheric pressure, temperature, light intensity and soil movement. Sensed data is then transferred and stored continuously in real time at base station. Any unusual change in environment and disaster can be observed via abnormal values of the parameters. This work focuses to provide an inexpensive yet real time monitoring approach for agrarian purposes as well as alert for catastrophic situations.

Keywords: Real Time (RT); Environmental Parameters (EP); Wireless Sensor Node (WSN); LabVIEW.

1. Introduction

Sensor networks have enormous scope and applications. Its significance increases specifically in the domain of environmental monitoring [1, 2].

* Corresponding author email: aly.ikram1@gmail.com

The environmental monitoring is crucial because the changes in environment can indicate the upcoming anomalous behavior which can be in the form of Tsunami, floods, cyclones, land sliding etc. [3, 4]. Motivation is devised from recent trends in the increase of climatic catastrophes which have been countered with autonomous alert systems to keep the life and property loss to its absolute minimum. One of the major areas of environmental monitoring is detection and prediction of abnormalities.

The Drought Forecast and Alert System (DFAS) has been presented in 2006 [5]. Here the prime focus is the use of Wireless Sensor Nodes (WSN) that deploys terrestrial and satellite network to collect and transmit environmental data aimed at global audience. Similarly in other works on standalone basis, soil parameters are monitored in 2011 [6], land slide systems, agricultural and organic compound monitoring systems have been presented in 2009, 2011 and 2012 respectively [7- 9]. Unlike to the sensor network presented in [10], which sends only appropriate (filtered) data by analyzing in Environmental Sensor Network (ESN), this proposed system sends all the data continuously in real time, even unusual values are being sent continuously thus increasing the sensitivity of the system. Special sensors have been developed for detecting floods, tsunami etc. in reference [11], but this problem can be simplified by just detecting changes in environmental parameters as stated earlier. Due to large power consumption of sensors, most of the systems are designed to fall and remain in hibernate state when there are no desired values like in reference [12], but this proposed system continues to monitor in real time due to its low power consumption during operations.

This work is aimed for continuous monitoring of the variations in environmental parameters while keeping the cost of prototype model to minimum. In this paper, key environmental parameters are measured simultaneously and data received is being stored continuously in database at base station and alert system activates if any environmental parameter exceeds the defined safe range.

2. Block Diagram

The parameters that are being monitored in this paper are Temperature, Soil Moisture, Light Intensity, Atmospheric Pressure and Soil movement. Field Processing Unit (FPU) is the portable monitoring entity of proposed system which transmits measurements wirelessly to the base station where these changes can be monitored in real time. This unit is very diverse; any sensor can be added or dropped as per requirement of the user. The sensing of soil movement will enable to monitor earthquake precursor wave, body waves (that travel within Earth i.e., primary and secondary waves) which are not recorded by conventional seismic meter. In addition, monitoring pressure and soil movement can also enable to detect any abnormality in soil that leads to land sliding.

Data measured in the FPU is being sent via ZigBee (transceiver) module which is inexpensive wireless channel and consumes less power and hence can operate in extended period of time. Network topologies such as mesh, star, hybrid and tree are supported in ZigBee [13, 14]. The transceiver has been set in this design because its main application base is low power transmitter and receiver. It is configured using XCTU ver. 5.2.8.6 provided by Digi International Inc. At the receiving end, transceiver is interfaced with PC's USB 2.0 port via CP2102 USB to UART Converter by Silicon Laboratories Inc [15].

Transceiver and sensors data alignment has been discussed in reference [16]. The power requirement of the designed FPU is low as a simple 164 mA battery is enough to run this system.

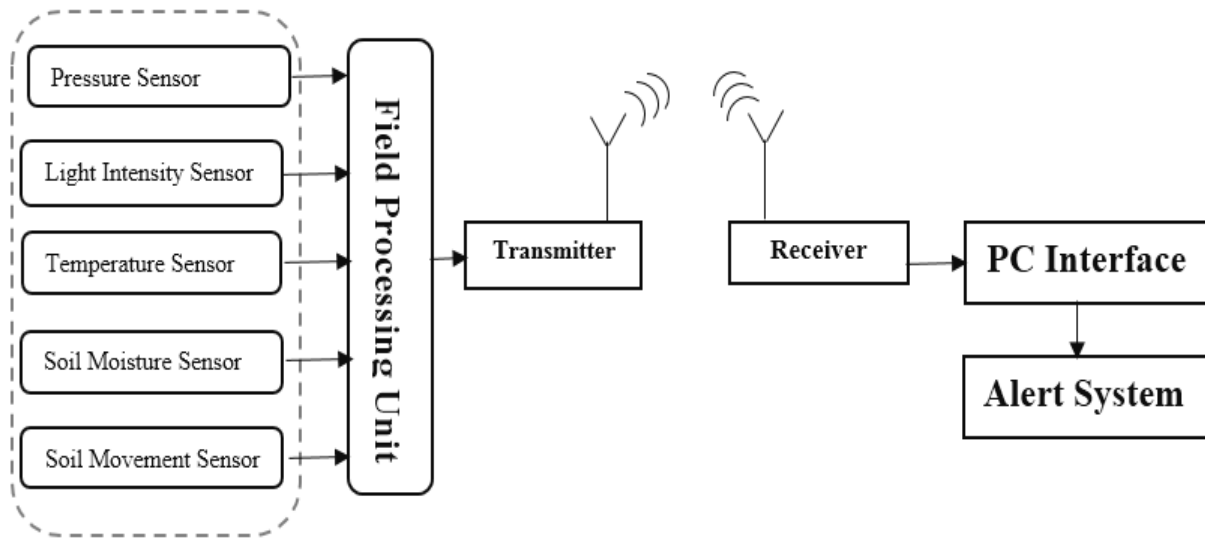

Figure 2.1: Block Diagram

The block diagram of proposed system is shown in Figure 2.1. All sensors (Temperature, Atmospheric pressure, Light Intensity, Soil movement, Soil moisture) are connected to FPU (Arduino mega 2560). All sensors send compensated analogue values. ZigBee (Transmitting module) is connected to Arduino Microcontroller. Data is digitalized and then serialized, after that it is transmitted to receiving side, where it is stored in database and viewed by Graphical User Interface. In case of anomalies in data alert system activates. The alert system is consist of visual indicators and siren sound.

3. Methods and Materials

This system consists of five sensors namely Atmospheric pressure sensor, Temperature sensor, Light intensity sensor, Soil moisture sensor, and Soil movement sensor. Compensated analogue values from sensors are fed into the microcontroller (Arduino) from where digital values are transmitted serially via transmitter (Zig Bee).

3.1 Atmospheric Pressure and Temperature Sensor

Atmospheric Pressure and Temperature are measured by the sensor BMP 085 (known as Digital Pressure Sensor). It is a low cost, low power and highly accurate sensor manufactured by Robert Bosch. It has Piezo- resistive crystal embedded with 3.3 required volts. It is a linear sensor which is directly calibrated by the data stored in its ROM. It has pressure range of 300-1100 hPa (9000m to -500m above sea level) with up to 0.03hPa / 0.25m resolution. It has temperature range of -40 to +85°C operational range, with temperature in steps of 0.1°C [17]. Sensor requires 5µA at 1 sample/sec if used in standard mode. Output of sensor is connected with ADC of microcontroller Mega for further processing and wireless transmission.

3.2 Soil Moisture Sensor

Sensor used to measure soil moisture is Sunkee Soil Hygrometer [18]. This is a user friendly, water sensor module which has been used to detect soil moisture. The principle is like that of potentiometer. The resistance varies by changing level of soil moisture and the output of the sensor is high when the soil is moisture deficit and vice versa. This sensor is low cost, linear and has high accuracy. It outputs a different voltage levels for different level of soil moisture with. Its range of operating voltage is between 3.3V to 5V. Like BMP 085, it has been calibrated by repetitive experiments and coding is done in Arduino. Soil moisture module is placed to measure the extent of moisture in the given medium. In the Digital Output (DO) interface port; threshold ranges are defined and stored. Normally its output is high, in case the humidity goes beyond the limit; the module DO interface gives low output. This sensor is interfaced with the microcontroller to detect the two states, low and high judging is on the basis value calibration.

3.3 Light Intensity Sensor

Set of Light Dependent Resistor (LDR) have been used as a solar radiation sensor in this work. Several experiments had to be done because the conversion of lux to irradiance in W/m^2 is complicated procedure. 100W filament light bulb has been used as light source for calibration experiments. There is a direct relationship between the effective frontal area where the light is projected (*lux*) and the resistance of the LDR (R_L) given by,

$$R_L = 500/lux \quad (3.1)$$

With the LDR connected to 5V through a 3.3 k Ω resistor, the output voltage of the LDR given by equation 3.2

$$V_o = 5R_L/(R_L+3.3) \quad (3.2)$$

Reworking the equation, light intensity can be obtained as

$$lux = (1/3.3)(2500/V_{o-500}) \quad (3.3)$$

Hence an easy and quick method to find light intensity has been developed. This sensor was then retested with other light sources as well.

3.4 Soil Movement Sensor

The phenomenon of Peak Ground Acceleration (PGA) has been monitored using accelerometer. The relationship between gravitational acceleration and the peak ground acceleration is (1 gravity = 981 Gal), so it makes calibration of soil movement simple. Hence accelerometer is used. Accelerometer is advantageous over other schemes because

- It gives acceleration in all three dimensions.
- Orientation can be found corresponding to acceleration caused by seismic activity.
- This scheme is practically more realizable.

The values are then fed to Arduino for calibration and digitalized for transmission. The accelerometer will be played by an ADXL345 from analog devices. This is a low power 3-axis accelerometer which is accurate to measurement at ± 16 g [19].

It will require a supply voltage of 1.8 V to 3.6 V; will give output in the x, y, and z directions providing little cross axis sensitivity. This will send a digital signal to the DE2 board that represents the acceleration felt by the sensor. This means any motion, shock, or vibration will be detected and recorded on the DE2 board.

3.5. Power Consumption of the System

Atmospheric Pressure and Temperature parameters are measured by BMP 085 which requires voltage of 2.5V, current of $3\mu\text{A}$ and total power of 0.007mW. Soil Moisture Sensor requires 3.3V and 3mA of current with total power of 9.9mW, similarly soil movement sensor required 0.1mW but our system is getting supply from Arduino output pins with total power consuming 0.325W (supplied to Arduino with 5 Volts and 65mA current) in addition with ZigBee requiring 0.495W (3.3 volts and 150mA current) so total power required in this proposed system is $0.325\text{W} + 0.495\text{W} = 0.82\text{W}$

3.6. Graphical User Interface (GUI)

LabVIEW is used at the receiver end because of its high versatility and a Graphical User Interface (GUI) has been developed for visual programming and excellent real time response. The data from all sensors is received serially via com port which is then separated by associated identification key. The data received is unpacked, processed and fed into respective graph for displays and data logging, front panel of RT-MEP has been developed for continuous monitoring. Front panel of GUI consist of graphs and meters to show readings for specific interval of time and instantaneous readings respectively. A safe operation range indicator is also developed in GUI to alert the user of any abrupt change or abnormality in the system.

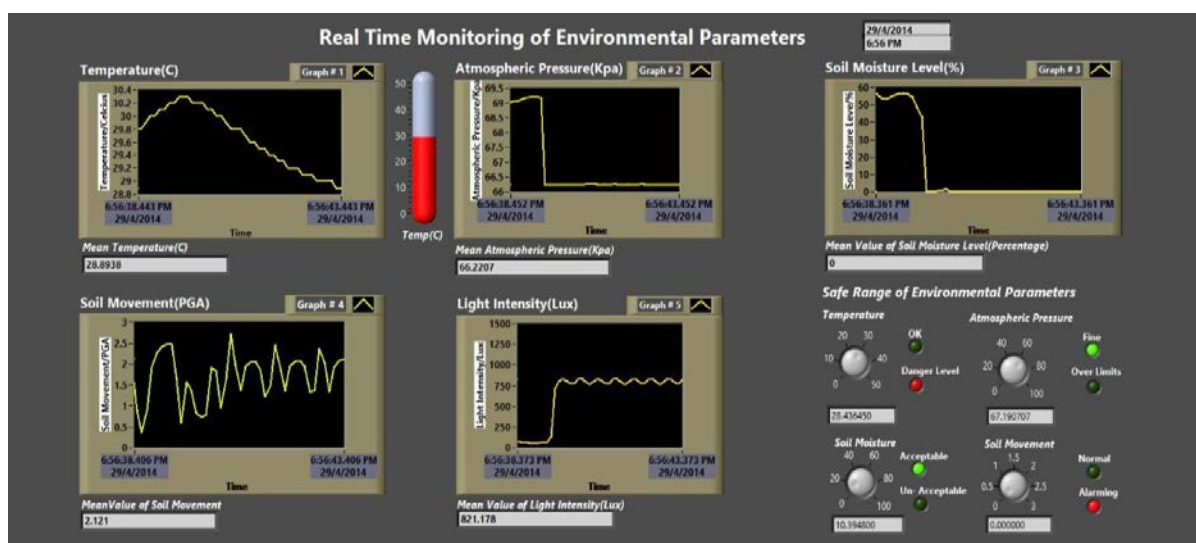

Figure 3.2: Graphical User Interface (GUI)

4. Indoor Setup for System Performance Assessment

The indoor setup that is built on moveable base and made up of different rocks. It contains fan, heat source, moisture source and radiation source to measure pressure, temperature, humidity and light intensity respectively. Moveable base is used to generate vibrations in order to observe peak ground acceleration phenomenon. This setup was built to observe system response in controlled environment.



Figure 3.3: Indoor Setup for System Performance Assessment

5. Results and Discussion

5.1. Atmospheric Pressure Sensor

Results of atmospheric pressure plotted against real time are shown in Figure 4.1. The hardware assembly is continuously operating. The graph is mostly constant over the range of experiments showing consistency of atmospheric pressure. The sudden change in pressure is observed in experiment, this was artificially created by bringing a high speed fan near the sensor and then removing it in order to record the real time response. The system responds quickly toward external variations and changes were observed on to the base station with a delay of 1500 ms. The results are counterchecked by barometer and correlation between these two results is 0.991

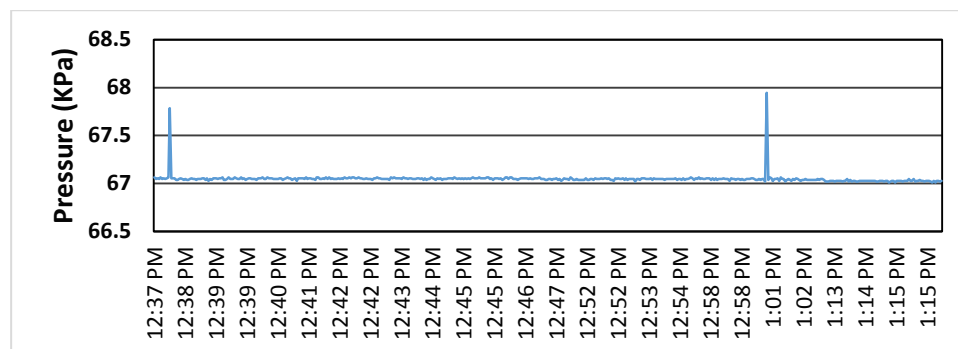

Figure 4.1: Pressure sensor

5.4. Light Intensity Sensor

Results obtained for light intensity plotted against the real time in figure 4.4. This graph shows a lot of variation in light intensity. Light Intensity was varied by switching 100W lamp and results were compared with lux meter. The results were found highly accurate to 1500 lux and then due to limitation of linear response of LDRs, the results started to vary. Hence this scheme of light sensing works very well at low light intensity and can be used as indicator to sense solar irradiation. Light intensity, temperature and moisture are the most important parameter that are constantly monitored in greenhouses.

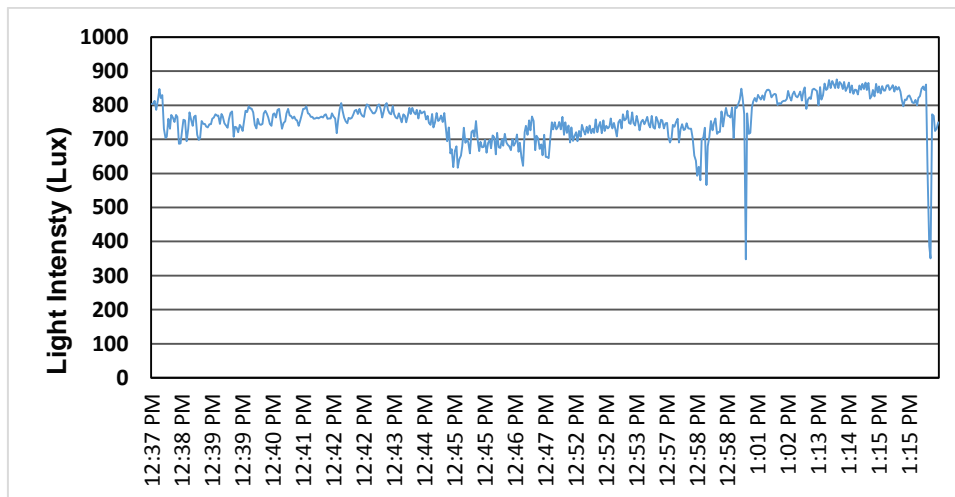

Figure 4.4: Light intensity sensor

5.5. Soil Movement Sensor

Real time plot of Peak Ground Acceleration against time is displayed in figure 4.3. The soil movement is measured as a function of Peak Ground Acceleration (PGA). Various ranges of PGA corresponding to the intensity of soil movement are as follows:

0.001 g (0.01 m/s²) – perceptible by people

0.02 g (0.2 m/s²) – people lose their balance

0.50 g – very high; well-designed buildings can survive if the duration is short [20]. The artificial vibrations are created by moving the base of indoor experimental setup in which accelerometer is installed. The base is then disturbed initially from low intensity to a high intensity and readings are tabulated.

5.6. Safe Range Indicator and Alert System

A safe operating range portal is developed so that a user can set the maximum safe limit of any parameter by adjusting the knob.

In Figure 4.6, the LEDs indicate whether a particular parameter at any given instance is under safe limits or not (White Led indicates that the parameter is in the limits set by the user and Black Led indicates that particular parameter is not within safe limit). This portal has application of alert system required in some sensitive environments such as food storage depot, laboratories etc.

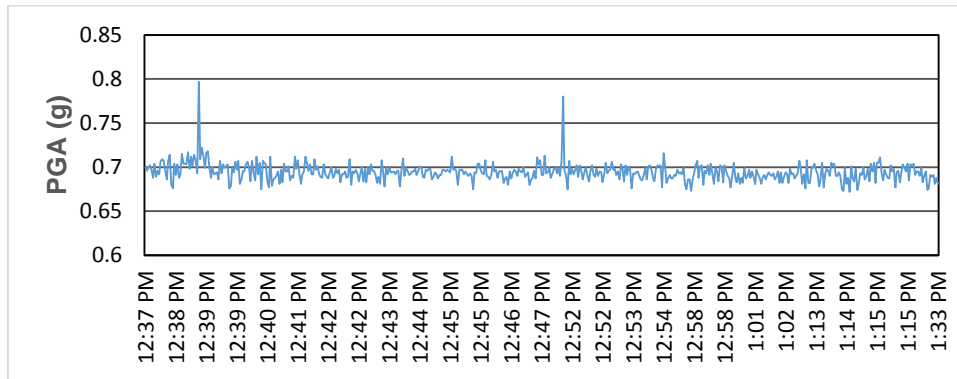

Figure 4.5: Peak ground acceleration sensor

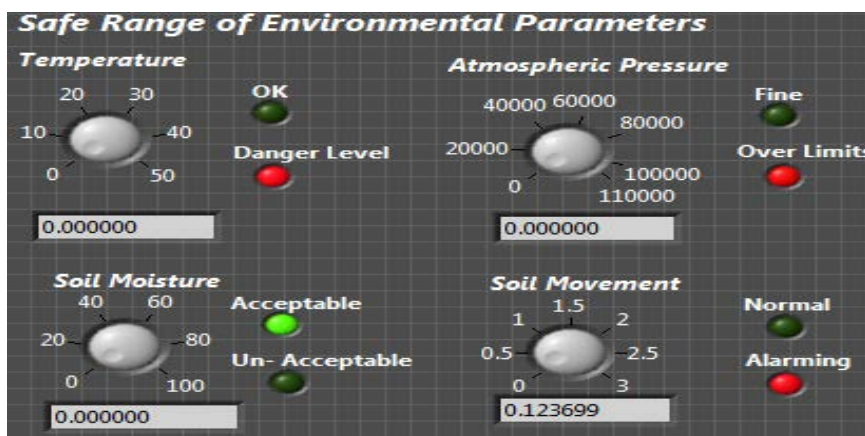

Figure 4.6

5.7 Database and Analysis

Along with the real time results, a database has been also established where all the results are updated and stored in real time for easy referencing which has increased the worth of this proposed system. Database includes 10 readings per minute of each sensor .Spikes in these graphs are due to sudden changes in external physical to be measured by sensors. GUI is used for real time monitoring whereas database provides complete data over large time span that is required for environmental analysis and anomalous predictions.

6. Conclusion

In this paper, a low cost and user friendly setup has been developed which monitors environmental parameters continuously in real time. The system devised is flexible, autonomous, and portable and has optimized hardware.

Thus proposed system is extremely suitable for remote locations. The prototype, after undergoing series of experiments, has been found fully capable of recording changes in real time. The added feature of data logging provides the cross referencing capability, hence providing an excellent tool for researchers who are looking for data to correlate changes in environmental parameters and its effects on life. The parameters which have been measured are of utmost importance, much of environmental changes taking place are due to their varying behavior. The system formed is very economical solution to the areas that are concerned with photovoltaic parameter monitoring, sustainable cultivation fields, wildlife and disaster monitoring.

References

- [1] Budde, M.; Berning, M.; Busse, M.; Miyaki, T.; Beigl, M., "The TECO Envboard: A mobile sensor platform for accurate urban sensing — And more," Networked Sensing Systems (INSS), June 2012
- [2] Buratti, C.; Conti, A.; Dardari, D.; Verdone, R.; "An overview on wireless sensor networks technology and evolution, *Sensors*", vol. 9, pp. 6869–6896. 2009
- [3] Emetere, M.E.; "Monitoring and Prediction of Earthquakes using Simulated Temperature Deviation Curve Model", *International Journal of Applied Information Systems, Foundation of Computer Science FCS, New York, USA Volume 4– No.3, September 2012.*
- [4] Xiao long Sun, Yaowei Liu, "Changes in groundwater level and temperature induced by distant earthquakes", *Geosciences Journal Vol. 16, No. 3, p. 327 – 337, Beijing China, September 2012.*
- [5] Kung, H.; Hua, J.; Chen, C.; "Drought Forecast Model and Framework Using Wireless Sensor Networks", *Journal of Information Science and Engineering, Vol 22, Pages 751-769, 2006.*
- [6] Montrasiol, L; Ferrari, G.; "A Distributed Wireless Soil Displacement Measurement System for Active Monitoring of the Excavation Front of a Gallery", *The Open Electrical and Electronic Engineering Journal, 5, 1-8, 2011.*
- [7] Ramesh, M.V.; "Real-time Wireless Sensor Network for Landslide Detection", *Proceedings of The Third International Conference on Sensor Technologies and Applications, SENSOR COMM 2009, IEEE, Greece, June 18 - 23, 2009.*
- [8] Wang, Z.; Zhao, C.; Zhang, H.; Fan, H.; "Real-Time Remote Monitoring And Warning System In General Agriculture Environment" *Proceedings of IEEE International Conference of Information Technology, Computer Engineering and Management Sciences, 2011.*
- [9] Manes, G.; Collodi, G.; Fusco, R.; Gelpi, L.; Manes, A.; "A Wireless Sensor Network for Precise Volatile Organic Compound Monitoring", *International Journal of Distributed Sensor Networks Volume 2012.*
- [10] Hart, J.K.; Martinez, K.; "A revolution in the earth system science". *Earth Science Reviews, July 2006.*
- [11] Barker, S.; Adriaanse, M.; Chilton, J.; Diop, S.; Ipsen, N.H.; Igarashi, S.; Jimbow, T.; Kariya, S.L.; Maurer, T.; Meybeck, M.; Roberts, R.; Yamashiki, Y.; "Improving Global Water Quality Monitoring: UNEP GEMS/Water Technical Advisory Paper", vol. 1, pp. 1–18. Bernard, E.N., 2004.
- [12] Kothari, D.; Thakker, M.; Shah, V.A.; Gohel, T.; "A Real Time Wireless Multi –Parameter monitoring System with ZigBee and LabVIEW". *International Journal of Current Engineering and Technology, Dec 2013.*
- [13] Torresen, J.; Renton, E.; Jensenius, A.R.; "Wireless Sensor Data Collection based on Zig Bee Communication, Conference on New Interfaces for Musical Expression (NIME 2010), Sydney, Australia, 2010.

- [14] Pang, N.; "Zig Bee Mesh Network for Greenhouse Monitoring", Proceedings of IEEE International Conference on Mechatronic Science, Electric Engineering and Computer PP266-269 August 2011.
- [15] VijayaLaxmi, H.; Narender, M.; "Communication b/w Mobile Robots and PC controller Based On ZigBee Network", International Journal of Engineering Research and Applications, Vol. 1, Issue 4, pp.1432-1435, ISSN: 2248-9622. December 2013.
- [16] Hassan A.K.; Hoque A.; Moldsvor A., "Automated Micro-Wave (MW) antenna alignment of Base Transceiver Stations: Time optimal link alignment", Australasian Telecommunication Networks and Applications Conference (ATNAC), Melbourne, Australia, December 2011.
- [17] Sensortec, B.; GmbH, "Digital Pressure Sensor" SMD500 datasheet, October 2009.
- [18] <http://electron-space.blogspot.com/2013/09/soil-moisture-sensor-soil-hygrometer.html>, Date Accessed Feb 2014.
- [19] Analogue Devices, "Digital Accelerometer", AXDL345 datasheet, February 2014.
- [20] Lorant, G.; "Seismic Design Principles", Whole Building Design Guide, National Institute of Building Sciences. March 2011