



International Journal of Sciences: Basic and Applied Research (IJSBAR)

ISSN 2307-4531
(Print & Online)

<http://gssrr.org/index.php?journal=JournalOfBasicAndApplied>



Estimation SOC for Li-Ion Batteries in EVs Using EKF

Ashkan Kavash*

Kathmandu University, Budol, Nepal

Email: akavashfard@yahoo.com

Abstract

Recently, secondary batteries have attracted a lot of attention. They have been used as an energy source in electric vehicles (EVs), hybrid electric vehicles (HEVs) and smart grids. This attention increases by emerging more demand for decreasing CO₂ gas in the air and having more renewable source. For those applications for rechargeable batteries and specifically Li-ion chemistry based ones, the battery management system (BMS) needs to have a very close to the truth guess of state of charge (SOC) of each individual cell in the battery pack. This research paper presents an extended Kalman filter based method to estimate SOC of Li-ion batteries. The validity of the procedure is demonstrated experimentally for an APR18650m1 LiFePO₄ battery.

Keywords: Extended Kalman Filter (EKF); State of Charge (SOC); Li-ion batteries; nonlinear filter; EV.

1. Introduction

For electrical energy storage, secondary batteries are one of the most first choices. This potential have gained due to those batteries ability to respond fast to energy demand, energy efficiency, and their availability. the worldwide demand for reduction in CO₂ pollution, emerging renewable energy sources like solar panels and wind farms and finally increasing number of Electrical Vehicles (EVs) in streets, advanced battery systems have been proposed for a wide range of applications varying from EVS, hybrid electric vehicles (HEVs) to smart grids [1].

* Corresponding author.

E-mail address: akavashfard@yahoo.com..

Among different possible chemistries for secondary batteries in the market, Li-ion batteries have several advantages over NiMH and lead acid ones and gain more popularity. These advantages include higher energy density, less weight, longer cycle life than those of systems based on NiMH or lead acid. An appropriate battery model is necessary for proper design, engineering and operation of these battery systems require [2]. A lot of models have been proposed in the research world that are sufficiently accurate to show electrical behavior of Li-ion batteries [3-6]. These models need to rely on parameters of the battery such as SOC, which is an inner state of the battery [7], to allow them working properly. In recent years, different methods are proposed by many researchers to improve the estimation of the SOC [8].

Lots of effort have been used to improve accuracy of SOC estimation. Coulomb counting method is the most common method used to estimate SOC [9-10]. However, this method has several disadvantages like sensitivity to the initial SOC value that could be inaccurately estimated and the accumulated error due to its integration nature [1, 10]. In addition to this method, a number of intelligent approaches has been developed in an attempt to achieve a more accurate SOC estimation, such as sliding mode observer [11,12], and the neural network method [13,14], and others methods have been investigated.

For control and vehicle power management, accurate estimation of SOC is important [15,16]. However, in most of the estimation methods described above, the effect of current flow direction, SOC and temperature on the battery model parameters are not considered. Meaning that, the robustness of these SOC estimation algorithms has not been sufficiently assessed. More than that, a more strong method is needed to guess the SOC of a lithium ion cell.

EKF is known to be optimal for handling recursive mathematical equations in nonlinear systems such as those encountered in Li-ion batteries. In this paper, first the electrical model to estimate Li-ion battery have been presented. Later on, EKF haven explained and is used to estimate SOC for Li-ion batteries used in EVs. Last section, concludes the paper.

2. Electrical model of the battery

SOC, as one of the most important information in BMS used in EVs, smart grids and robots [17-20] that cannot be measured directly during battery operation. As a result, estimating SOC is the only way to derive its value. To estimate this value, a battery model must be chose.

To capture Li-ion battery performance for different applications, a variety of battery models have been developed. Among those models, the electrochemical models and the equivalent circuit models, are widely used in electrical engineering goals. The electrical circuit models to predict I-V characteristics of batteries, use voltage and current sources, capacitors and resistors. For this work we have used the electrical model presented in [4] as the battery model. This model is shown in Fig. 1. In this model, energy balance circuit is a part of model which delivers SOC to the voltage response circuit. In this model, the ohmic resistance R_o consists of the bulk resistance and surface layer impedance, accounting for the electric conductivity of the electrolyte, separator and electrodes, the activation polarization is modeled by R_s and C_s , and the concentration polarization is

presented by R_l and C_l .

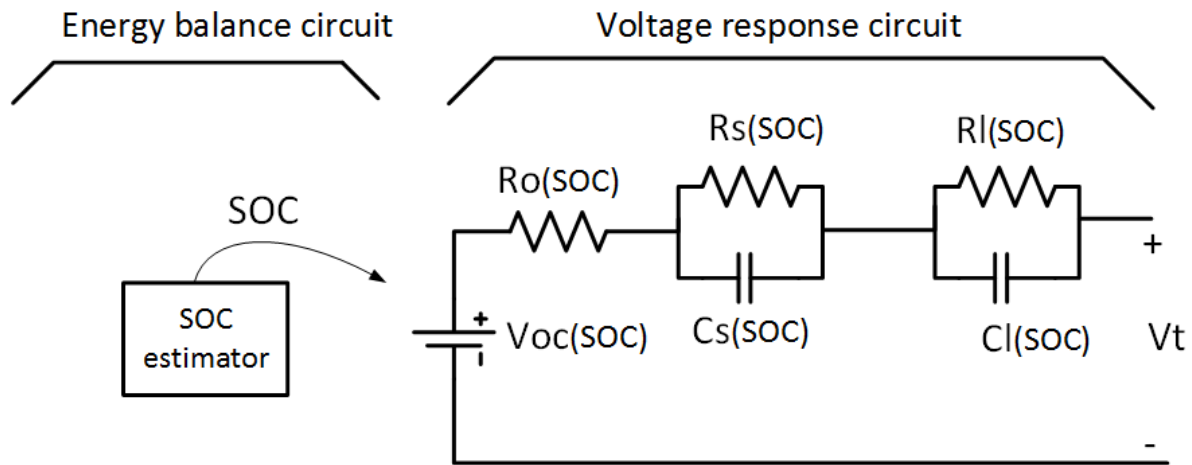

Figure 1: Electrical model for the Li-ion battery.

To increase the model's complexity, in this work the model's components are assumed to be function of SOC. It is assumed that for charging and discharging, this model follows the same equations.

The following equations, express the electrical behavior of the practical model:

$$V_t = V_{OC} - V_{trans} - R_o I_L \quad (1)$$

$$V_{trans} = V_s + V_l \quad (2)$$

$$\dot{V}_s = -\frac{1}{R_s C_s} V_s + \frac{1}{C_s} I_L \quad (3)$$

$$\dot{V}_l = -\frac{1}{R_l C_l} V_l + \frac{1}{C_l} I_L \quad (4)$$

In these equations, V_t is the battery terminal voltage, V_{OC} is the battery open circuit voltage (OCV), I_L is charging/discharging current. V_s and V_l are respectively the short and long time transient voltage responses for charging/discharging.

3. Extended Kalman filter

Kalman filter (KF) is a well-known estimation theory introduced in 1960 is [16]. KF provides a recursive solution through a linear optimal filtering to guess systems' state variables. However, in case of nonlinear systems, a linearization process will be used to approximate the nonlinear system with a linear time changing system at each step. Using this system in KF, would result in an extended Kalman filter (EKF) on a real

nonlinear system [23]. Following equations is shown in equations (5) and (6) are for nonlinear systems:

$$x_{k+1} = f(x_k, u_k) + w_k \quad (5)$$

$$y_{k+1} = g(x_k, u_k) + v_k \quad (6)$$

where (5) is all of the system dynamics represented in state equations, (6) the output equation of the system with a static relationship. Function $f(x_k, u_k)$ and $g(x_k, u_k)$ are nonlinear transition function and nonlinear measurement function, respectively. Vectors w_k and v_k denote process and measurement noise, respectively. For each time step, matrices of $f(x_k, u_k)$, and $g(x_k, u_k)$ are linearized close to the operation point by the first order in Tyler-series and the rest of series are truncated. Assuming that $f(x_k, u_k)$, and $g(x_k, u_k)$ are differentiable at all operating points and $A_k = \frac{\partial f}{\partial x} |_{x=\hat{x}}$, $C_k = \frac{\partial g}{\partial x} |_{x=\hat{x}}$. Later on, as shown in equation (7), EKF starts filtering with the available information on the initial state (\hat{x}_0^+) and error (P_0^+) covariance.

$$\hat{x}_0^+ = E[x_0], P_0^+ = E[(x - \hat{x}_0^+)(x - \hat{x}_0^+)^T] \quad (7)$$

The Kalman filter, as shown in Figure 2, includes two steps, i.e., a prediction step and a correction step. During the prediction step, the filter predicts the value of the present state, system output, and covariance using the process model. During the correction step, the filter improves the estimated/predicted state and the error covariance using an actual output measurement from the output model. Since the predicted estimate is calculated before the present measurement is taken, it is called a priori estimate. The corrected estimate is called a posteriori estimate because it is calculated after the present measurement. In terms of notation, a superscript “-” denotes a priori estimate while a superscript “+” denotes a posteriori estimate, and \hat{x} denotes a state estimate.

In figure 2, \hat{x}_k^- is the priori state estimate at step time k and P_k^- is its corresponding priori covariance. K_k is the Kalman gain matrix, \hat{x}_k^+ is the posteriori state estimate at step time k, and P_k is its corresponding posteriori covariance matrix. In summary, the Kalman filter uses the entire observed input data $\{u_0, u_1, \dots, u_k\}$ and measured output data $\{y_0, y_1, \dots, y_k\}$ to find the minimum squared error estimate \hat{x}_k of the true state x_k [4].

4. SOC estimation using EKF

As mentioned in section 3, EKF is an optimum state estimator for nonlinear systems. Basically, EKF filters work with noisy measurement data and are not sensitive to the initial value's of states due to its feedback control. Moreover, it can be used for accurate battery SOC estimation [22]. As EKF is formed in discrete space, equations (5) and (6) are transformed to their discrete counterparts to estimate SOC in discrete space. Following the form of EKF, the state equations for the nonlinear system of the battery are obtained as $x_1=Vs$, $x_2=VI$ and $x_3=SOC$.

As mentioned in introduction section, SOC as one of these states can not be measured directly. However, the charging/discharging current I_L and battery's terminal voltage V_t can be measured. Discrete time state space

form for practical model after linearization of equations (5) and (6) are shown in (7) and (8).

$$x_{k+1} = A_k x_k + B_k I_{L,k} + w_k \tag{7}$$

$$V_t = y_k = C_k x_k + D_k I_{L,k} + v_k \tag{8}$$

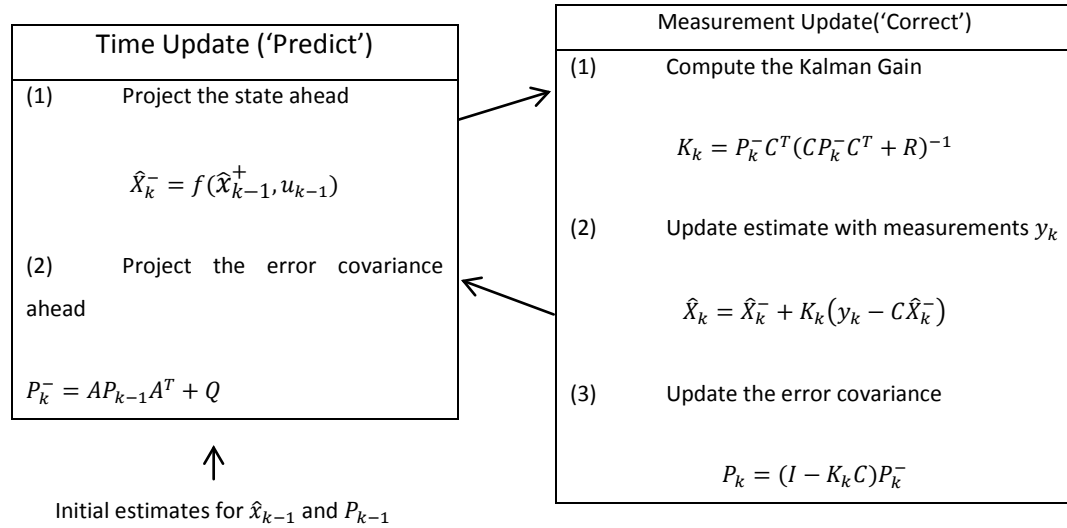

Figure 2: Complete picture of the operation of the extended Kalman filter [4]

the state vector of practical model consists of three state variables as shown in (9).

$$x_k = \begin{bmatrix} V_{s,k} \\ V_{l,k} \\ SOC_k \end{bmatrix} \tag{9}$$

where in above equation, SOC_k is the estimated SOC at time step k which is equal to:

$$SOC_k = SOC_{k-1} + I_{L,k} \Delta t / C \tag{10}$$

where Δt equals to sampling time, C is the usable capacity of the battery's available capacity. The matrixes A, B, C and D in equations (7) and (8) are defined as below:

$$A_k = \begin{bmatrix} e^{\frac{-\Delta t}{R_{s,k} C_{s,k}}} & 0 & 0 \\ 0 & e^{\frac{-\Delta t}{R_{l,k} C_{l,k}}} & 0 \\ 0 & 0 & 1 \end{bmatrix} \tag{11}$$

$$B_k = \begin{bmatrix} R_{s,k} \left(1 - e^{\frac{-\Delta t}{R_{s,k}C_{s,k}}} \right) \\ R_{l,k} \left(1 - e^{\frac{-\Delta t}{R_{l,k}C_{l,k}}} \right) \\ -\eta \Delta t / C_{usable} \end{bmatrix} \quad (12)$$

$$C_k = \left. \frac{\partial V_t}{\partial x} \right|_{x=\hat{x}_k^-} = \begin{bmatrix} -1 & -1 & \left. \frac{\partial V_{oc}}{\partial SOC} \right|_{SOC_k^-} \end{bmatrix} \quad (13)$$

$$D_k = [-R_{o,k}] \quad (14)$$

And state space equations output equals to:

$$y_k = V_{oc}(k) - I_{L,k}R_{o,k} - v_s - v_l \quad (15)$$

5. Simulation results

To confirm the validity of the proposed method for SOC estimation of Li-ion batteries and to compare the EKF method with the conventional coulomb counting method, a set of charge/discharge experiments are conducted on a Li-ion battery. This Li-ion battery is an APR18650ml LiFePO₄ battery with 1.1Ah nominal capacity. It is assumed that tests are done at room temperature.

Figure 3 presents the estimated terminal voltage using the proposed EKF method along with the SOC estimation error. This test has been done at room temperature, cell was fully charged and discharging current is 1C (1.1A).

In the EKF filter the initial parameters for P and Q as follows:

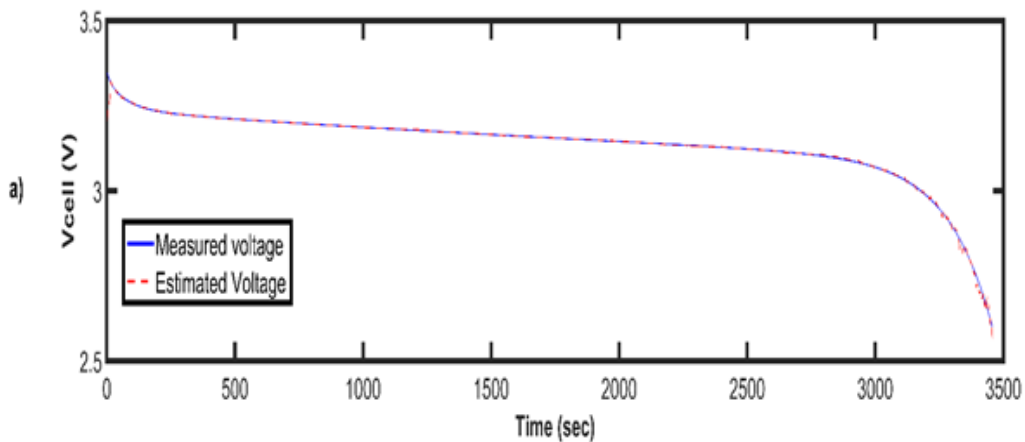

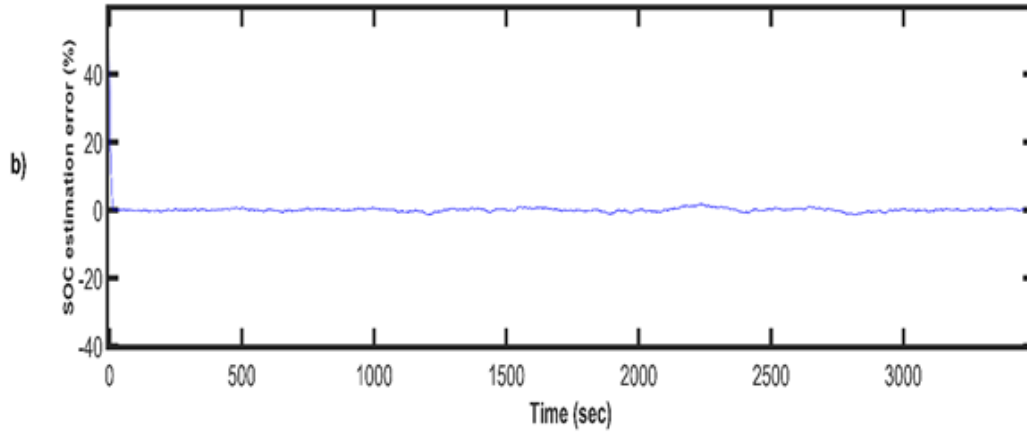

Figure 3: EKF estimation for a new cell's (a) terminal voltage and (b) SOC discharged with 1C (1.1A)

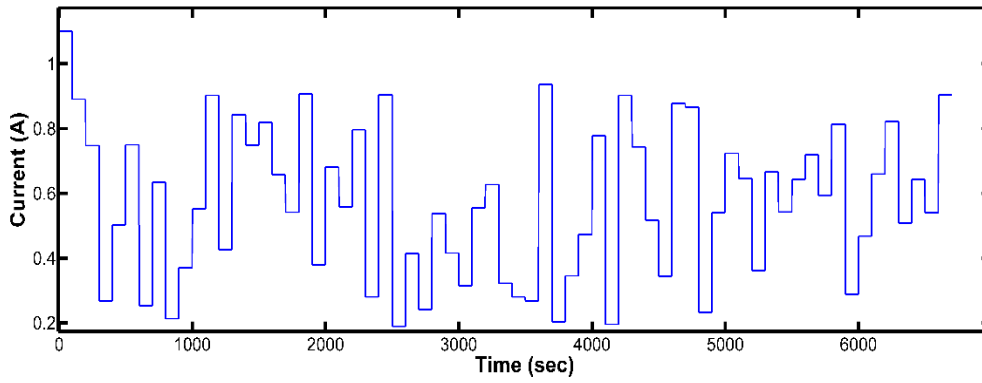

Figure 4: Current profile for the last experiment

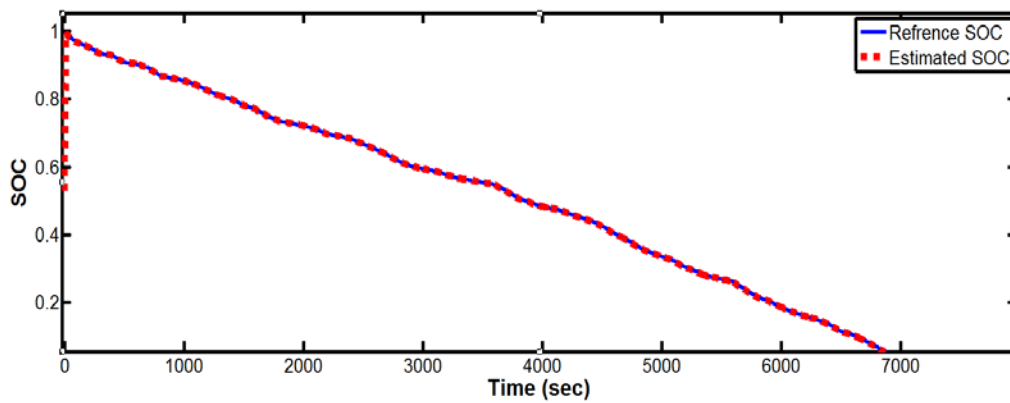

Figure 5: SOC estimation for a fully charged cell discharge with current profile presented in Figure 5.

The actual performance observed for the EKF is consistent with the behavior of its associated covariance matrix, computed from the algorithm in the Figure 2. SOC estimation error by EKF.

Next test has been done with current profile presented in Figure 4 on a fully charged cell. The EKF starts estimation from 50% and converges to real SOC very fast. According to experiment results the EKF is able to estimate SOC and cell's terminal voltage with mean error less than 1.1% and 44mV, respectively. Reference SOC and estimated SOC by EKF is presented in Figure 5.

6. Conclusion

This paper proposed a more universal form of battery modeling and SOC estimation method called EKF. For this goal the problem is formulated, and existing literature is reviewed. Then an equivalent circuit is used to model the battery, and an EKF approach is developed to estimate the state of charge. The proposed approach has been verified using different current. Based on battery test data, simulation results are presented to support the validity of the proposed estimation method. This approach could also be applied to other kinds of batteries and components. Using this approach SOC estimation error for the tested Li-ion cell is less than 4%. For future, to cover more practical conditions, temperature effect will considered on the model to estimate the SOC by EKF.

References

- [1] Lotfi, Nima and Landers R. G. "Robust nonlinear observer for state of charge estimation of li-ion batteries." *ASME 2012 5th Annual Dynamic Systems and Control Conference joint with the JSME 2012 11th Motion and Vibration Conference*. American Society of Mechanical Engineers, 2012.
- [2] Sepasi, Saeed, Reza Ghorbani, and Bor Yann Liaw. "SOC estimation for aged lithium-ion batteries using model adaptive extended Kalman filter." *In Transportation Electrification Conference and Expo (ITEC)*, 2013 IEEE, pp. 1-6. IEEE, 2013.
- [3] Liaw, Bor Yann, Ganesan Nagasubramanian, Rudolph G. Jungst, and Daniel H. Doughty. "Modeling of lithium ion cells-a simple equivalent-circuit model approach." *Solid state ionics* 175, no. 1 (2004): 835-839.
- [4] Sepasi, Saeed, Reza Ghorbani, and Bor Yann Liaw. "A novel on-board state-of-charge estimation method for aged Li-ion batteries based on model adaptive extended Kalman filter." *Journal of Power Sources*, 245 (2014): 337-344.
- [5] Lam, Long, Pavol Bauer, and Erik Kelder. "A practical circuit-based model for Li-ion battery cells in electric vehicle applications." *In Telecommunications Energy Conference (INTELEC)*, 2011 IEEE 33rd International, pp. 1-9. IEEE, 2011.
- [6] Yamazaki, T.; Sakurai, K.; Muramoto, K., "Estimation of the residual capacity of sealed lead-acid batteries by neural network," *Telecommunications Energy Conference, 1998. INTELEC. Twentieth International* , vol., no., pp.210,214, 1998

- [7] Lotfi,N. Fajri,P. Novosad,S. J. Savage, R. G. Landers, M. Ferdowsi. "Development of an Experimental Testbed for Research in Lithium-Ion Battery Management Systems." *Energies* 6.10 (2013): 5231-5258.
- [8] Zhao, Yunlan, Haitao Yun, Shude Liu, Huirong Jiao, and Chengzhen Wang. "State-of-charge Estimation for Lithium-ion Batteries Using a Multi-state Closed-loop Observer." *Journal of Power Electronics* 14, no. 5 (2014): 1038-1046.
- [9] Waag, Wladislaw, Christian Fleischer, and Dirk Uwe Sauer. "Critical review of the methods for monitoring of lithium-ion batteries in electric and hybrid vehicles." *Journal of Power Sources* 258 (2014): 321-339.
- [10] Sepasi, Saeed, "Adaptive state of charge estimation for battery packs", University of Hawaii at Manoa, DEC 2014.
- [11] Han, Huachun, Haiping Xu, Zengquan Yuan, and Yingjie Zhao. "State of Charge estimation of Li-ion battery in EVs based on second-order sliding mode observer." In *Transportation Electrification Asia-Pacific (ITEC Asia-Pacific), 2014 IEEE Conference and Expo*, pp. 1-5. IEEE, 2014.
- [12] Kim, Il-Song. "The novel state of charge estimation method for lithium battery using sliding mode observer." *Journal of Power Sources* 163, no. 1 (2006): 584-590.
- [13] Xia, Bizhong, Chaoren Chen, Yong Tian, Wei Sun, Zhihui Xu, and Weiwei Zheng. "A novel method for state of charge estimation of lithium-ion batteries using a nonlinear observer." *Journal of Power Sources* 270 (2014): 359-366.
- [14] Sepasi, Saeed, Reza Ghorbani, and Bor Yann Liaw. "Improved extended Kalman filter for state of charge estimation of battery pack." *Journal of Power Sources* 255 (2014): 368-376.
- [15] Zhang, Xi, and Chris Mi. "Analytical Approach for the Power Management of Blended Mode PHEV." In *Vehicle Power Management*, pp. 107-139. Springer London, 2011.
- [16] Zhang, Bingzhan, Chris Chunting Mi, and Mengyang Zhang. "Charge-depleting control strategies and fuel optimization of blended-mode plug-in hybrid electric vehicles." *Vehicular Technology, IEEE Transactions on* 60, no. 4 (2011): 1516-1525.
- [17] G. Marangoni. "Battery management system for li ion batteries in hybrid electric vehicles". Padova, 2010.
- [18] Shafiei, S. E., and S. Sepasi. "Incorporating sliding mode and Fuzzy controller with bounded torques for set-point tracking of robot manipulators." *Electronics and Electrical Engineering.–Kaunas: Technologija* 8 (2010): 104.
- [19] Davodi, Moez, Ehsan Reihani, and Mehdi Davodi. "Application of hierarchical clustering method for separation of power system." *International Journal of Power and Energy Conversion* 2, no. 3 (2010): 279-288.

[20] E. Kamal, A.El Hajjaji and A. Mpanda Mabwe. "State of charge estimation based on extended kalman filter algorithm for lithium-ion battery." In 23rd Mediterranean Conference on Control and Automation, IEEE, (2015) pp. 1-6.

[21] R. E. Kalman. "A New Approach to Linear Filtering and Prediction Problems". Transactions of the ASME – *Journal of Basic Engineering*, 82:35-45, 1960.

[22] G. Welch and G. Bishop. An introduction to the Kalman Filter, Available: <http://www.cs.unc.edu/welch/kalman/kalmanIntro.html>.