



# International Journal of Sciences: Basic and Applied Research (IJSBAR)

ISSN 2307-4531  
(Print & Online)

<http://gssrr.org/index.php?journal=JournalOfBasicAndApplied>



---

## MCU-Based Multi Parameter Patient Monitor

Abdullah Alsadig M. Adam <sup>a\*</sup>, Magdi B. M. Amien <sup>b</sup>

<sup>a</sup>*Faculty of Engineering, Elneelain University, Khartoum +249, Sudan*

<sup>b</sup>*Faculty of Engineering, University of Gezira, medani+249, Sudan*

<sup>a</sup>*Email: klibesh29@yahoo.com*

<sup>b</sup>*Email: magdy\_baker@yahoo.co.uk*

### Abstract

The patient monitoring system presented in this research is able to detect, process, display, four essential clinical parameters; body temperature, blood pressure, Electro Cardiogram (ECG) interpretation, and heart rate, to inform the patient and the physician in short time, using an advanced low cost design, low power consumption and high accuracy methodologies. The proposed device intended to be placed in the intensive care unit (ICU), and the produced signal will be processed by microcontroller (AVR) and then displayed results in graphical LCD (GLCD).

**Keywords:** Patient monitoring systems (PMS); AVR microcontroller; GLCD.

### 1. Introduction

A medical monitor or physiological monitor or display, is an electronic medical device used in medical monitoring that measures a patient's vital signs and displays the data so obtained, which may be transmitted on a monitoring network. Physiological data are displayed continuously on GLCD screen as data channels along the time axis. The patient monitoring system is an essential diagnostic tool that measures and records the various physiological activities of the human body. A wide range of body Condition can be detected when interpreting the body signals. This quality makes the patient monitoring system a perfect instrument for diagnosis and supervision at operation theatres and ICUS.

---

\* Abdullah Alsadig M. Adam.

E-mail address: klibesh29@yahoo.com.

In critical care units of hospitals, bedside units allow continuous monitoring of a patient, with medical staff being continuously informed of the changes in general condition of a patient. Some monitors can even warn of pending fatal cardiac conditions before visible signs are noticeable to clinical staff, such as arterial fibrillation or premature ventricular contraction [4 5]. The goal of the proposed project is to design a portable, easy to use, high affiance, low powered and very high accuracy, multi-function patient monitor that has four parameters.

**2. History of Physiological data measurements**

A sphygmomanometer or blood pressure meter was invented by Samuel Siegfried Karl Ritter von Basch in 1881. It comprised of an inflatable cuff to restrict blood flow, and a mercury or mechanical manometer to measure the pressure. It is always used in conjunction with a means to determine at what pressure blood flow is just starting, and at what pressure it is unimpeded. Typically they are used in conjunction with a stethoscope. Scipione Riva-Rocci introduced a more easily used version in 1896 that was a wall-mounted mercury manometer linked to a balloon-inflated cuff that would measure the pressure needed to compress arterial systolic blood pressure measurement. Harvey Cushing discovered this device in 1901 and popularized it. Within the framework in the development of medical devices and patient vital signs monitoring, Nihon Kohden introduced Japan's 1st ICU patient monitoring system in the year of 1967. The ICU-80 system monitored patients using a bouncing spot CRT monitor, analog meters, strip-chart recorders, and switches for monitoring each patient's parameters. It was later redesigned for easy waveform and parameter value monitoring with a memory oscilloscope and digital displays. Today's systems are compact and versatile, requiring little maintenance [6].

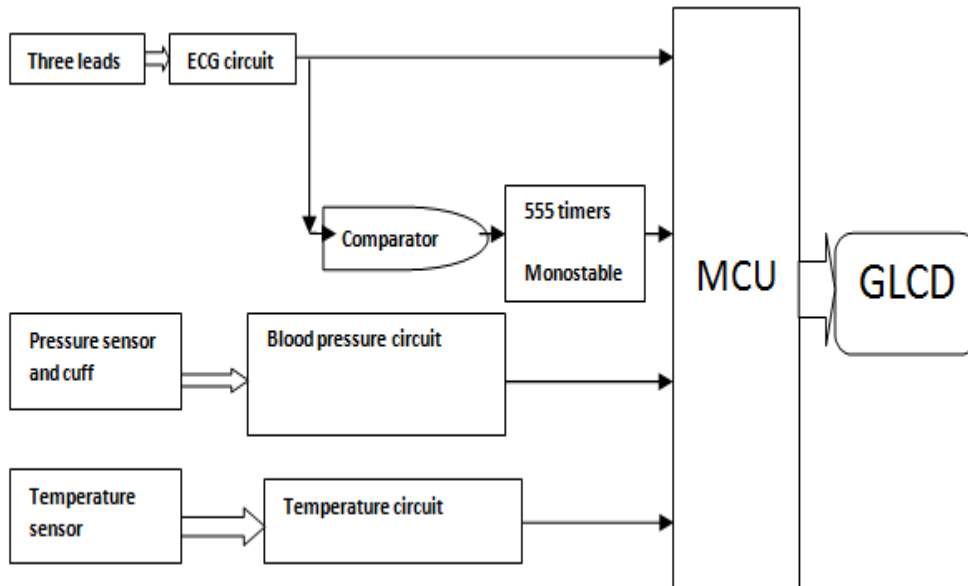

Fig. 1. System block diagram

### 3. System design and implementation

The system consists of four front-end analog circuitry assembled in smart board, it acquires three signals, to generate four parameters; body temperature, blood pressure, ECG interpretation, and heart rate. The system core is AVR microcontroller which is based on Harvard architecture; and capable of handling the concerned signals, realizing, analyzing and displaying the desired data on a graphical LCD (GLCD), the proposed device will operate using a  $\pm 9$  volt output battery.

#### 3.1 Bio-potential signals detecting

We are going to use tree kinds of sensors; the first sensor is to detect the (ECG) signal by using surface electrode which placed on the skin of patient's three limbs. The second sensor is silicon piezo-resistive pressure sensors (MBX2050). The sensor is a single monolithic silicon diaphragm with the strain gauge and a thin-film resistor network integrated on-chip. The chip is laser trimmed for precise span and offset calibration and temperature compensation; this provides a highly accurate and linear voltage output directly proportional to the applied pressure. The last sensor (DS18B20) DALLAS MAXIM is a temperature sensor which has the capability to work with an Atmel AVR microcontroller, with the unique one Wire-Bus interface requires only one pin for communication.

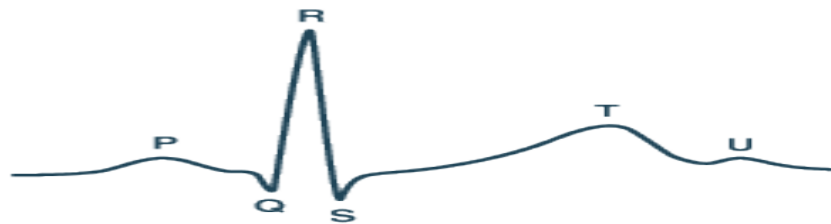

Fig. 2. normal ECG signal

#### 3.2 Signal amplifying

By using biological signal amplifiers which are designed to convert the weak voltage signal generated by various biological processes for example; heart muscle activity in ECGs, into a strong signal. Almost every biological signal amplifier is built from an integrated circuit instrumentation amplifier. In the case of this research, we have relied on a specific type of amplifiers (TLC2274) to build up a number of amplifying circuits, except in the case of pre amplifier for ECG we used AD620.

#### 3.3 Signal extraction

In the case of measuring the blood pressure, we used a band-pass filter stage designed as a cascade of the two active band-pass filters, with cut-off frequency ranges between 0.338Hz and 6.631Hz. The reason for using two stages is that the overall band-pass stage would provide a large gain and the frequency response of the filter will have sharper cut off than using only single stage. This method will improve the signal to noise ratio of the output. An AC coupling stage is used to provide the DC bias level. We want the DC level of the waveform to

locate at approximately half of its input voltage, which is 2.5V. By using this bias level, it is easier for us to process the AC signal using the on-chip Analog to Digital Converter (ADC) in the microcontroller. To filter the ECG signal we are going to use three filtering stages, the first one is a second order high pass filter to eliminate the very small voltages that is near to the zero volts, and the cut-off frequency is (0.02Hz). The second stage of filtering the signal is a second order low pass filter; we use it in order to filter the frequencies that are higher than 40Hz. And the final stage of this ECG diagram is a twin notch filter, which is designed for elimination of the 50Hz frequency. This frequency comes with the electricity lines, and makes a great source of noise. We don't need any external components to extract the signal from the temperature sensor because of its unique features. In the paragraph below we will discuss each department separately.

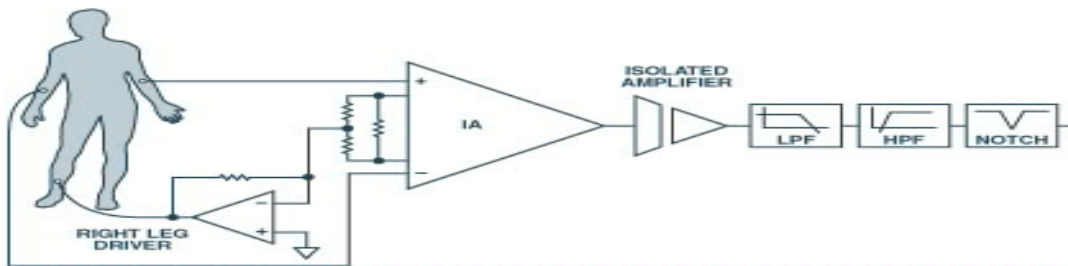

Fig. 3. ECG block diagram

### 3.4 ECG Circuit design

In the case of measuring the heart signal we have used three leads; the placement of the electrodes on the body determines the view of the vector as a function of time. The figure below represents the most basic form of the electrode placement which is based on Einthoven's triangle. This theoretical triangle is drawn around the heart with each apex of the triangle representing where the fluids. Around the heart connect electrically with the limbs. As we can see in Lead I measure the differential potential between the right and left arms, Lead II between the right arm and left leg, and Lead III between the left arm and left leg.

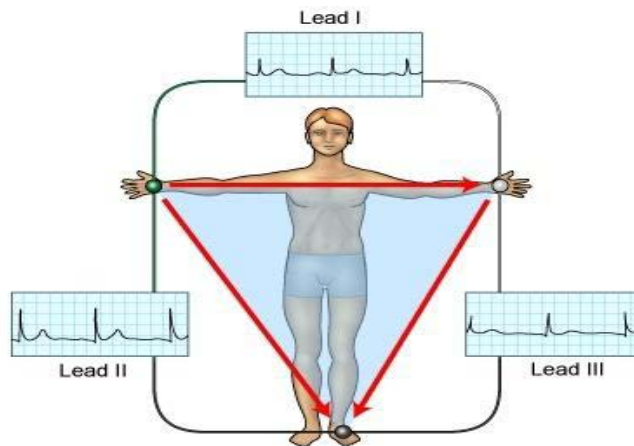

Fig. 4. Einthoven's triangle

Based on the objectives related to design and described previously we have designed an analog circuit consists of two parts placed on a serial bases, the first part is an initial stage of amplification the biological signal using (AD620). And the second part of the design is a multi-stages signal filtering using three types of filters; high-pass filter, low-pass filter and a notch filter respectively. The figure demonstrates a general design of ECG circuit. Now we represent a detailed demonstration of each stage of the design.

**3.4.1 AD620 pre-amplifier**

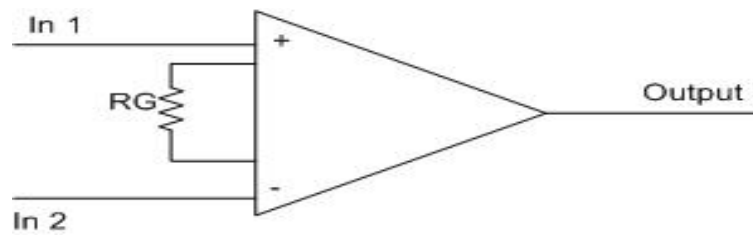

Fig. 5. Pre-amplifier AD620 schematic diagram

Figure 4 above shows the schematic diagram of the pre-amplifier AD620, The resistor (RG) controls the gain of the pre-amp, and in this case our gain is 10. The value of the resistor is determined by the equation below:

$$R_G = \frac{49.4k\Omega}{G-1} \quad (1)$$

**3.4.2 High-pass filter:**

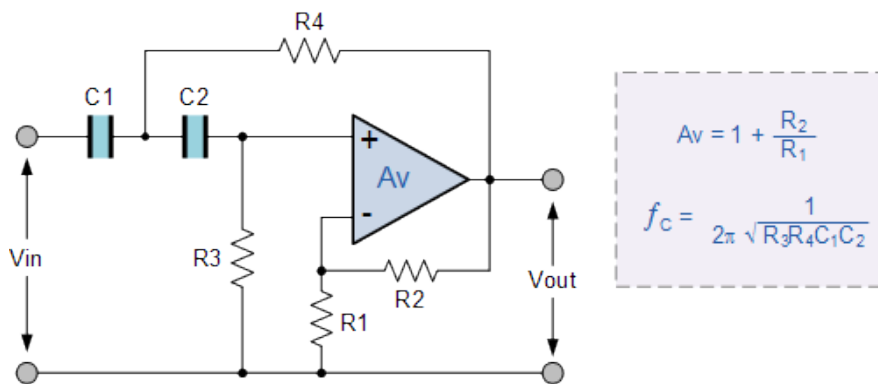

Fig. 6. second order high-pass filter

According to Eq. 2, we calculated the cut of frequency of the undesired low frequency signals;

$$f_{cutoff} = \frac{1}{2\pi\sqrt{R_1C_1R_2C_2}} \quad (2)$$

Figure 5 above shows a second order high-pass filter; this is simply designed by adding a resistor-capacitor (RC) network to a first order high-pass filter, the frequency response of the second order high-pass filter is identical to that of the first order type, except that the stop band roll-off will be twice the first order filters at 40dB/decade (12dB/octave). The equation to the right of the diagram describes how we control the voltage gain (AV), and the cut-off frequency (fC).

The actual values are:

R1= 3 KΩ, R2= 27 KΩ, R3=R4= 8.2 MΩ, C1=C2= 1μF, fC = 0.02Hz

### 3.4.3 Low-pass filter

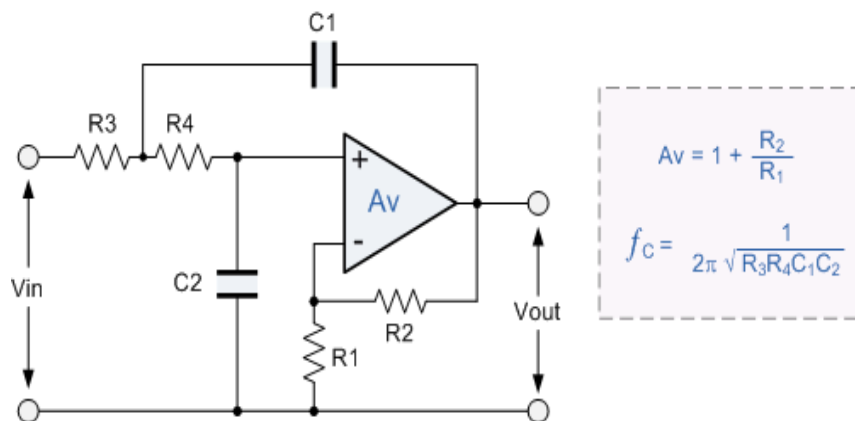

Fig. 7. second order low-pass filter

For the same reason of using a second order high-pass filter in the previous stage, we have used a second order low-pass filter to eliminate the undesired high frequency signals. The two equations to the right of the above diagram describe how we control the voltage gain (AV), and the cut-off frequency (fC).

The actual values are:

R1= 3 KΩ, R2= 27 KΩ, R3=R4= 6.8KΩ, C1=C2= 1μF, fC = 23.4Hz

### 3.4.4 Twin notch filter

This filter is designed to eliminate the 50HZ frequency that comes with the power sources; Fig. 8 shows the most common design of the twin notch filter.  $f_c$  is calculated the same way as the previous cut-off frequencies, and the values of resistors and capacitors are as follows:

$$R_1 = R_2 = 680K\Omega, C_1 = C_2 = 4.7nF, f_c = 50 \text{ Hz}$$

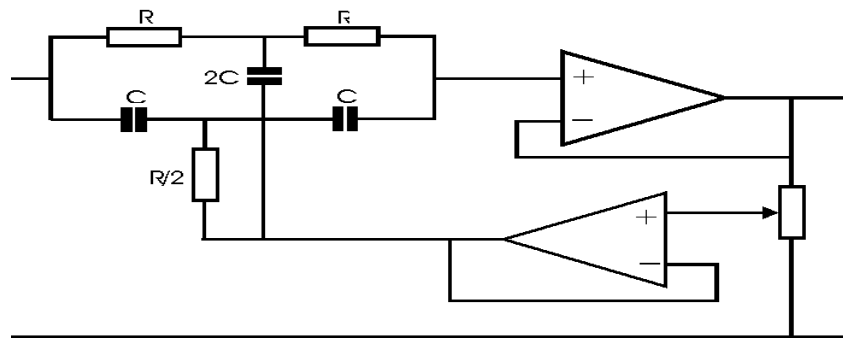

Fig. 8. Twin notch filter

### 3.5 Heart beat calculation unit design

This unit consists of two parts to convert the ECG signal to the square signal (pulses), and then the pulses calculated by MCU, which represents the number of heartbeat. First unit is a comparator.

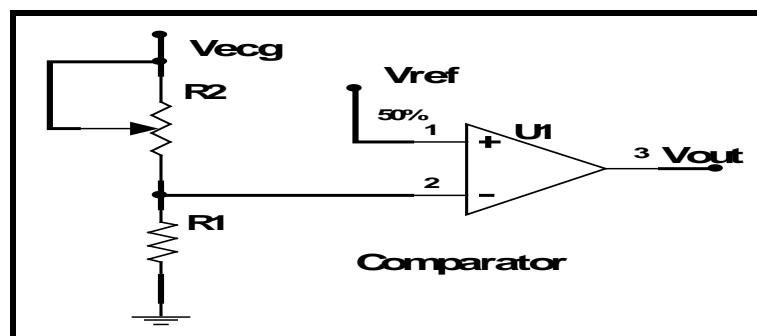

Fig. 9. Adjustable Comparator

An adjustable comparator is shown in above (Fig 9), where  $R_1 = 10k\Omega$ , potentiometer  $R_2 = 500k\Omega$ .  $R_1$  is

proposed here for the case the potentiometer R2 shorts. Now, a reference voltage and an input ECG signal are prepared for the comparison. Then, the comparator output a negative-going pulse whenever the R-wave slope exceeds the reference voltage since the ECG signal is applied on the negative input of operational amplifier U1. Using a voltage divider to set the ECG signal amplitude, this comparator can adjust the pulse width of the output.

Second unit is monostable, A monostable multivibrator is shown in Figure below, where R5= 10kΩ, potentiometer R1= 500 kΩ, C1= 0.33μf, C2= 0.01μf, U1 is 555 timer, and Vcc= 9 or 12 V. The monostable multivibrator, also known as a one-shot, provides a single output pulse of a specific time length when it is triggered from an external source.

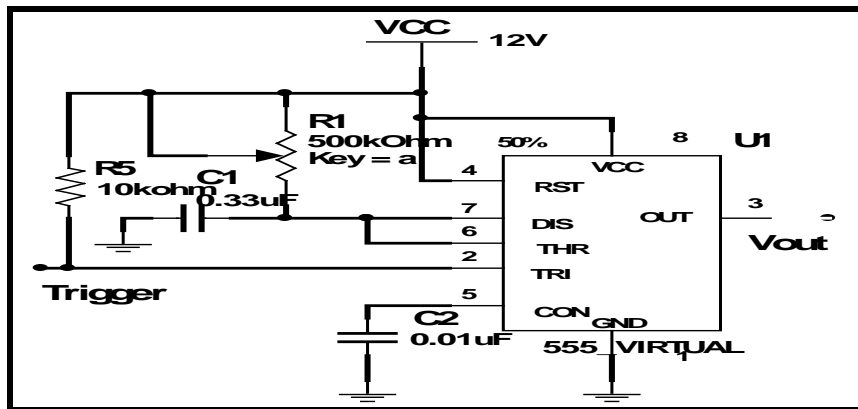

Fig. 10. Monostable Multivibrator

When the negative-going pulse coming from the comparator triggers the monostable, a stable positive pulse is generated on the output. The pulse time length is determined by equation below as follow.

$$T_w = 1.1 \times R_1 \times C_1 \quad (3)$$

The range of  $T_w$  is from 0 to 0.1815 second, which is still smaller than the minimum heart beat interval 0.2 second (300bpm). The R5 is a 10kΩ pull-up resistor that keeps the voltage on trigger high when there is no negative-going pulse.

### 3.6 Blood Pressure circuit design

As we demonstrated before; all the bio-signals that we will take from the one's body, will go through a multiple stages of amplifying and filtering, and the blood pressure signal is no difference. Figure below shows the blood pressure signal conditioning circuit.



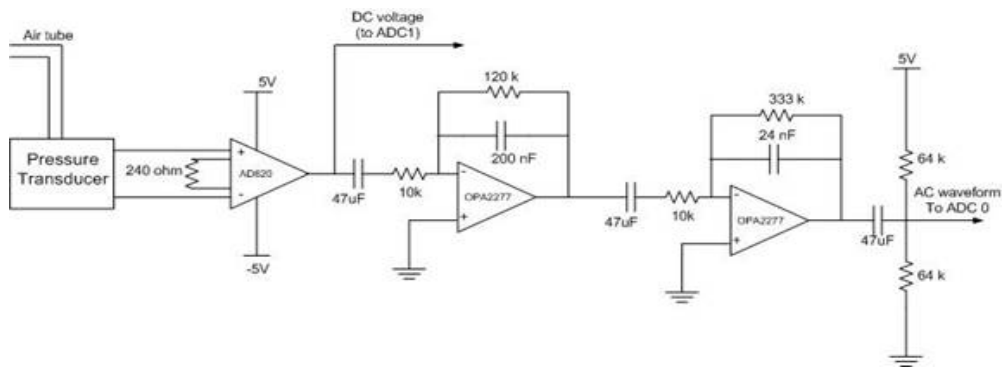

Fig. 11. Blood Pressure circuit diagram

The cuff is inflated until the pressure occludes flow within the brachial artery. As the pressure is released, blood begins to flow causing fluctuations (oscillations) in the arterial wall that are detected by the monitor. These oscillations increase in intensity then diminish and cease when blood is flowing normally. The monitor defines the maximal oscillations as mean arterial BP and then uses an algorithm to calculate systolic and diastolic BP, the cuff is placed as shown in Figure below [2].

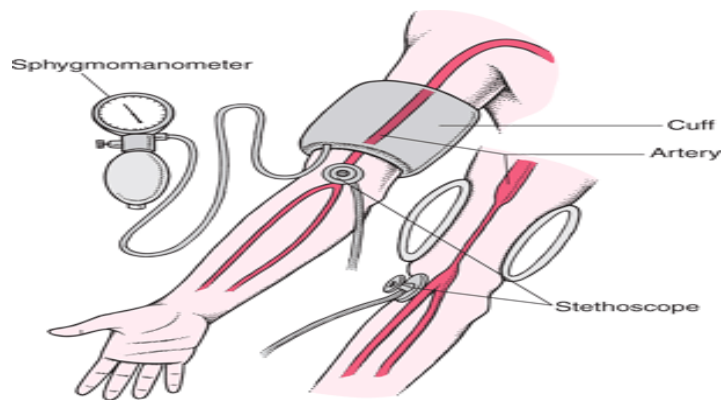

Fig. 12. Placement of the cuff and the stethoscope.

The band-pass filter stage is designed as a cascade of the two active band-pass filters (figure.11). The reason for using two stages is that the overall band-pass stage would provide a large gain and the frequency response of the filter will have sharper cut off than using only single stage. This method will improve the signal to noise ratio of the output. The threshold frequencies were calculated using Eq.2 and they are as follows:

$$f_{C1}(\text{low}) = 0.338\text{Hz}, f_{C1}(\text{high}) = 6.631\text{Hz}, f_{C2}(\text{low}) = 0.338\text{Hz}, f_{C2}(\text{high}) = 19.91\text{Hz}$$

The ac coupling stage is used to provide the DC bias level. We want the DC level of the waveform to locate at approximately half of its input voltage, which is 2.5 V. Given this bias level, it is easier for us to process the AC signal using the on-chip ADC in the microcontroller. The scheme of this coupling stage is illustrated in Fig.13.

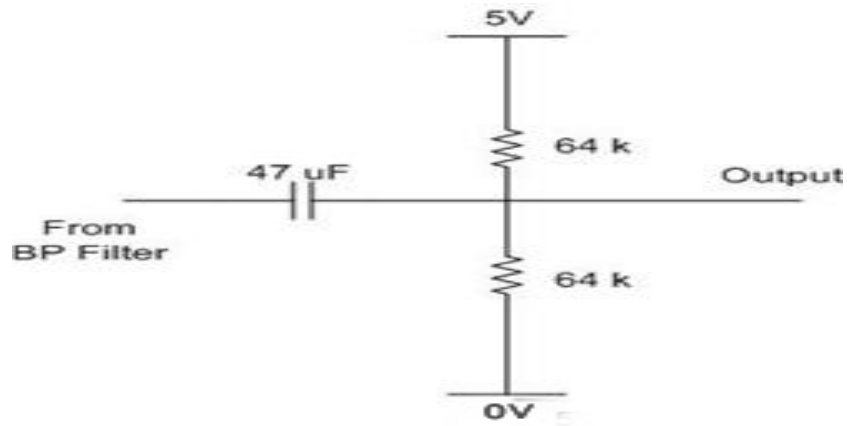

Fig. 13. an AC coupling stage

To calculate the systolic pressure we start pumping into the cuff until the pressure reaches 160 mmHg which is approximately more than the systolic pressure of normal healthy people, after reaches that pressure value we start deflating the cuff. When the pressure in the cuff decreases to a certain value, the blood begins to flow through the arm, and the systolic pressure can be obtained at this point [2].

Table.1. Body Temperature Regulation

Temperature (C)	Symptoms
28	muscle failure
30	Loss of body temp. control
33	loss of consciousness
37	Normal
42	central nervous system breakdown
44	death

### 3.7 Temperature unit

Temperature represents the thermodynamic state of a body, and its value is determined by the direction of the net flow of heat. It is one of the most important parameter of the human body which needs to be taken proper care.

Our temperature sensor package has only three pads; two of them are ground and VCC, and the data is transferred through only one wire and controlled by the microcontroller at a very precise intervals. Figure 14 shows the schematic of the (DS18B20) sensor package [3].

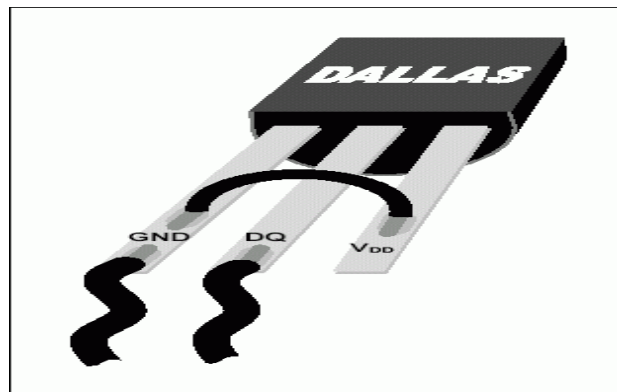

Fig. 14. Temperature sensor package schematic

### 3.8 Microcontroller unit

The main function of the CPU core is to ensure correct program execution. The CPU must therefore be able to access memories, perform calculations, control peripherals, and handle interrupts. In our implemented hardware, ATmega32 microcontroller is used. This device is a low-power CMOS 8-bit microcontroller based on the AVR architecture. The ATmega32 provides the many features including: 16Kbytes of In-System Programmable Flash Program memory with Read-While-Write capabilities, 32 general purpose I/O lines, 32 general purpose working registers, On-chip Debugging support and programming, three flexible Timer/Counters with compare modes, Internal and External Interrupts, a byte oriented Two-wire Serial Interface, an 8-channel, 10-bit ADC with optional differential input stage with programmable gain and six software selectable power saving modes [5 7].

In order to maximize performance and parallelism, the AVR uses Harvard architecture – with separate memories and buses for program and data. Instructions in the program memory are executed with a single level pipelining. While one instruction is being executed, the next instruction is pre-fetched from the program memory. This concept enables instructions to be executed in every clock cycle. The program memory is In-System Reprogrammable Flash memory. In our hardware design the pins are activated like:

\*Port A is used as an input for the ECG, the BP signals and temperature sensor.

\*Port B is used as a counter for the heart rate.

\*Port C is used to activate and to control the graphic LCD.

\*Port D is used also to activate and to control the graphic LCD.

The cross compiler that used to develop the embedded program for the proposed patient monitor is a mikroC PRO for AVR IDE (Integrated Development Environment) which is dedicated for ATMEL AVR family of microcontroller. In order to process the detected ECG signal we are using AVR ATMEGA32 with its inbuilt 10 bit ADC, which is needed for the conversion of the analog signals coming from the circuits. The ATMEGA32 could execute input-capture with a special pin, this pin calculates the square shape signal produced by the comparator with a clock reference of the MCU, and then the heart rate degree could be measured. We are using a temperature sensor which has only three pads two of them are ground and Vcc, and the data are transferred through the third wire to the microcontroller to be processed. When we set up this sensor on the MCU we just need to give some parameters, for example the read/write data, and the device does the rest. To calculate this pressure value, we set a threshold voltage of 4V for the AC waveform. At the start, there is no pulse and the voltage at the ADC0 pin is constant at approximately 2.5 V. Then when the pressure in the cuff decreases until it reaches the systolic pressure value, we then count the number of pulses that has maximum values above the threshold voltage. If the program counts up to 4, the program enters another phase, and records the DC voltage from pin ADC1. Then it converts this DC voltage value to the pressure in the cuff to determine the systolic pressure of the patient [3].

After taking the measures of the systolic pressure we find the program is still sampling the signal at every 40 millisecond. We then define the threshold for the diastolic pressure. To determine the diastolic pressure, we record the DC value at the point when the amplitude decreases to below the threshold voltage. This is done by looking at the time interval of 2 seconds. If the AC waveform does not go above the threshold in 2 seconds, it means the amplitude is actually below the threshold. The DC value can then be converted back to the pressure in the arm cuff using the same procedure as described in the Systolic Pressure Measurement above [2].

After the program finishes calculating the diastolic pressure, it will display the information acquired from the measurement on the GLCD.

### ***3.9 Display unit***

To display our signals and results we are using JHD12864E graphical LCD, This type of GLCD is standard 128×64 pixel matrix controlled by KS0108 LCD controller, capable of displaying numbers and letters, as well as graphics. The firmware part was written with the guidance of KS0108 controller's datasheet. To initialize the GLCD some sequential commands had to be maintained. For all the commands, first a given pattern was sent to the control pins. Then the data was sent to the data pins. The origin (0, 0) of the screen coordinates start from the top-leftmost pixel.

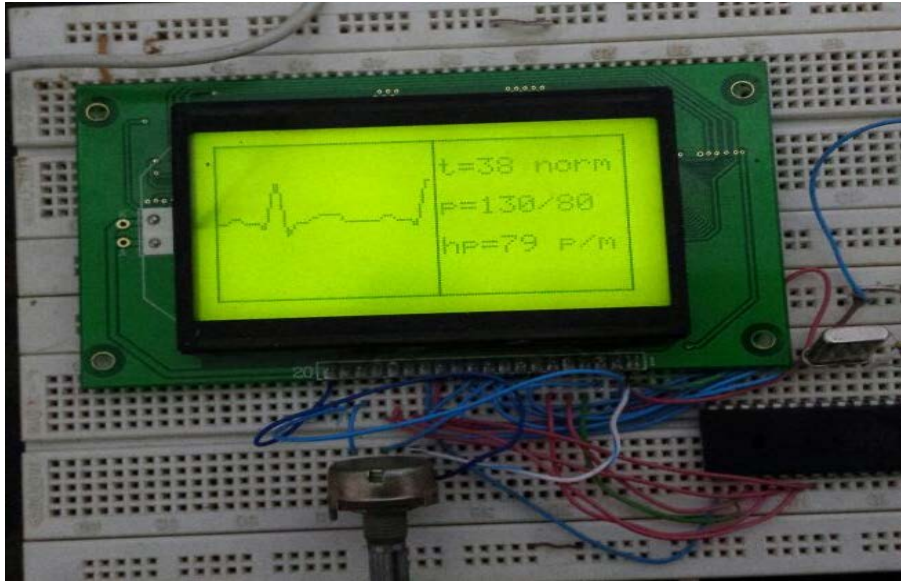

Fig. 15. GLCD interfaces with AVR MCU

#### 4. Results

In this paper, a MCU\_Based multi parameter patient monitor has been designed and implemented. It can be used in a clinical emergency room near the patients or at home, so that the ECG, temperature, pressure and heart rate can be displayed in graphical LCD (GLCD). The ECG signal was taken from an ECG Electrode through ECG conditioning circuit. The output of this circuit is conditioned to be in the range of (0 – 640) mV and applied to the AVR channel (ADC1), and the same output applied to the AVR channel (TCNT0) to calculate heart rate. The sensed patient temperature is conditioned and applied to AVR channel (ADC0). The blood pressure signal was taken from a pressure sensor (MBX2050) through conditioning circuit and applied to the AVR channel (ADC2). Were displayed all the values and the signal on the GLCD As in the figure below.

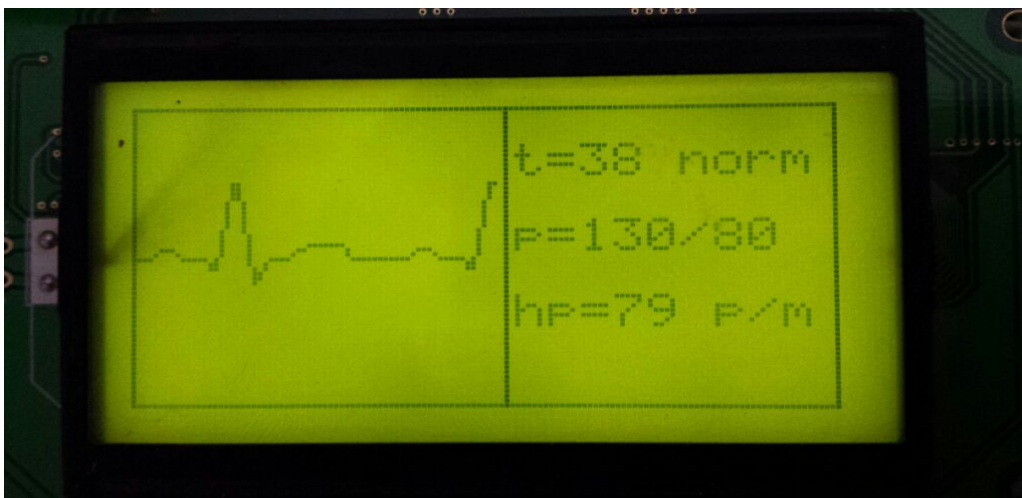

Fig. 16. GLCD showing ECG signal, temperature, heart rate and blood pressure

## **5. Conclusion**

This paper presents implementation and design of MCU\_Based multi parameter patient monitor. The goal of our project is to design a low powered patient monitor that will provide an accurate reading of one's heart rate, blood pressure, and temperature. This design will be easy to use, portable, and affordable. It will measure the heart rate from three leads connected to one's three limbs, and it will measure the blood pressure from cuff, finally we are going to use a temperature sensor to measure the body temperature. These three signals will be displayed on a graphic LCD.

Further signal conditioning may be performed in the MCU to reduce the noise. Besides, more facilities may be added in future, like transfer data to a PC directly, storing a large number of data in a SDRAM which can be read in a PC later. The design was successful in many aspects but we had a big problem with the noise in the signal, in our design we decreased the noise by using multiple filtering stages.

## **Acknowledgment**

To the light, our god, who guided us through the way To Dr. Magi Baker, for his great efforts of supervising and leading us, to accomplish this fine work. To our friends and families, they were a great source of support and encouragement; we thank them all and wish them all the best in their lives.

## **References**

- [1] A. Smruthy and E. smilyJeyaJothi. Pulse Transit Time Measurement Using ATmega16 Microcontroller, International Journal of Advanced Research in Computer Science and Software Engineering, vol.3, Issue 3, March 2013, EIE Department, Karunya University.
- [2] W. wattanapanitch and W. suampun, Portable Digital Blood Pressure Monitor, "unpublished".
- [3] G. MarullParetas, Using DS18B20 Digital Temperature Sensor on AVR Microcontrollers, Research Project Documents, September2007.
- [4] Winter BB and Webster JG: Reduction of interference due to common mode voltage in biopotential amplifiers. IEEE Trans.Biomed.Eng.1983; 30:58-62.
- [5] Timothy K.,Knilians, T.-C., Chou, L. S. R. , Electrocardiography in Clinical Practice Adult and Pediatric,WBSaunders;4<sup>th</sup>edition,1996
- [6] Bronzing, Joseph D. (Editor). The Biomedical Engineering Handbook. Boca Raton: CRC Press, Inc.,1995.
- [7] B.B. Flick & R. Orglmeister, A Portable Microsystem-Based Telemetric Pressure & Temperature Measurement Unit, IEEE TR on BiomedicalEngg.47 (1), 2000, 12-16.