



International Journal of Sciences: Basic and Applied Research (IJSBAR)

ISSN 2307-4531
(Print & Online)

<http://gssrr.org/index.php?journal=JournalOfBasicAndApplied>



Design and Implementation of Portable PC-Based ECG Machine

Abdullah Alsadig M. Adam^a, Magdy Baker M. Amin^b

^a*Faculty of Engineering, Elneelain University, Khartoum +249, Sudan*

^b*Faculty of Engineering, University of Gezira, medani+249, Sudan*

^a*Email: klibesh29@yahoo.com*

^b*Email: magdy_baker@yahoo.co.uk*

Abstract

The design and implementation of a portable PC based ECG system is discussed in this theses. ECG recording normally uses three-electrode – two for the differential inputs of the ECG amplifiers and the third for ground. Hence, low cost, low power, portability, and ease of use are factors that are considered at every stage of the design. This system explores a low power microcontroller, the ATMEGA32, manufactured by ATMEL Company for signal processing and sending digital format to PC with serial port and then displayed in PC throw labview software. This is a compact system capable of acquisition, amplification, filtering, and interpretation of biological signals (ECG). The proposed device intended to be placed in the intensive care unit (ICU).

Keywords: Type Labview, software, Intensive care unit, ECG, ATMEGA32.

1. Introduction

An electrocardiogram (ECG) is a recording of the electrical activity on the body surface generated by the heart. ECG measurement information is collected by skin electrodes placed at designated locations on the body.

* ABDULLAH ALSADIG M. ADAM.

E-mail address: klibesh29@yahoo.com.

The ECG signal is characterized by six peaks and valleys labelled with successive letters of the alphabet P, Q, R, S, T, and U. This article suggests some ideas for a low-cost implementation of an ECG monitor. Its configuration is envisaged for use with a personal computer (PC). Although this article is written with patient safety in mind, any ideas presented are not by themselves necessarily compatible with all system safety requirements; anyone using these ideas must ensure that, in a particular design, the design as a whole meets required safety criteria.[1]

PC-Based Patient Monitoring System provides essential information of person heart in order to detect various heart related disease. However, most of commercial ECG monitoring system has complicated function. Therefore, the problem to be studied is to design and implement the user -friendly system, attractive and can save time. Other problem is patient's vital signal measurement and data acquisition module. Besides that, the problem to be studied is the setup for interfacing ECG circuit to PC by using specific software. Other than that, is to prepare the coding that can be calculated the heartbeat rate. The patient monitoring system is developed especially for hospital usage, so the system needs to have a database for patient's data and confidentiality.

The goal of this project is to design and implement a PC- Based Patient Monitoring System. The system can acquires signals and displays ECG signal on the PC screen. Besides that, it also has a function to calculate the number of heart beats per minute based on ECG waveform obtained..

2. Methodology

To access proposed objective to design and implementation of portable PC based ECG, the following methodology has been followed: The system has six main stages: Signal amplifying, Signal extraction (filtering), processing, display, storages and Power supply, the Signal amplifying stage contains pre amplifier AD624, to make the biological signal good to measure and process, filtering stage contained low pass filter (LPF) and high pass filter (HPF) designed by LM324 this method will improve the signal to noise ratio of the output, The Atmega32L microcontroller is used as the processing unit to convert signal to digital value and send signal in PC throw serial within any second , A GUI designed by labview uses as display unit , and The proposed power supply unit was utilized two 5 ,+12,-12 volts by designed a low cost small adapter .

All the previous proposed ECG system it designed, simulated, built, tested and integrated. The integrated units were functionally and compatibly tested. The mikroC for AVR, and Proteus ISIS were utilized for developing the embedded code and simulating the proposed design. For prototype implementation, the real components were assembled on a breadboard, where a digital AVO meter was used for volts testing.

3. System Design

The proposed PC Based ECG is presented in Figure 1. the system has the following units: signal acquisition and filtering unit, processing unit, displaying and indicating unit, power supply unit., the units of the PC based ECG were designed, simulated, implemented and integrated. A proteus ISIS environment simulator was utilized to simulate the proposed ECG system as in Figure 2, where the implemented meter was achieved by using the breadboard.

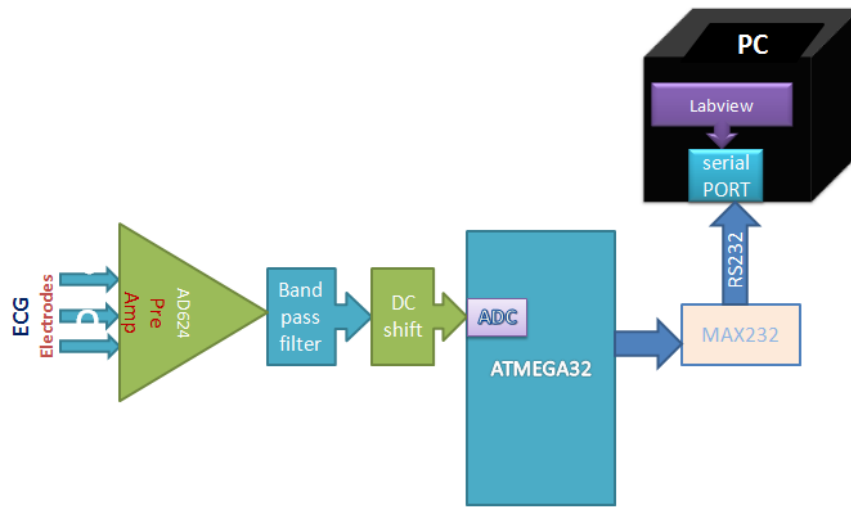

Fig. 1. System block diagram

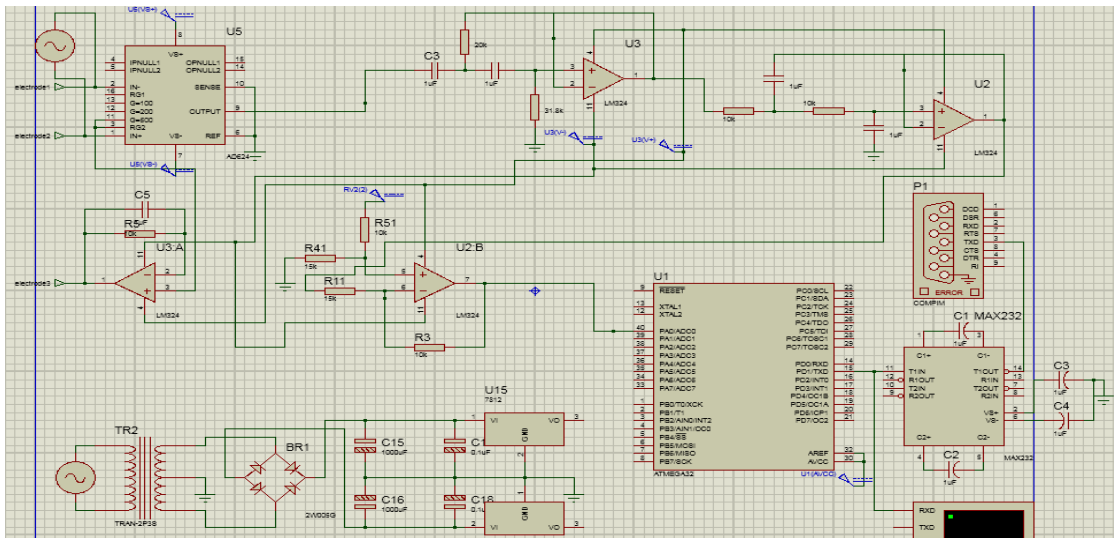

Fig. 2. System circuit diagram

3.1 The electrode

The first stage is the biopotential electrode, which converts the biopotential into electric signal. The common used silver-silver chloride electrodes are attached on the human body with electrolyte jelly. On the skin side of the electrode interface, a drift of ions is formed as the ECG signal spreads throughout the body. On the metal

side of the electrode, a little electric current is formed as the metal ions ionizing or unionizing to maintain an electronic potential equilibrium.

The result is a voltage drop across the electrode-electrolyte interface that varies depending on the electrical activity on the skin. This voltage drop causes electrons and anions to move across the interface into the skin. The differential potential between a pair of electrode is therefore formed.

One of the most important characteristics of electrodes is that they should not polarize. This means that the electrode potential must not vary considerably even when current is passed through them. Electrodes made of Silver-Silver Chloride have been found to yield acceptable standards of performance. These electrodes are also nontoxic and are preferred over other electrodes like Zinc-Zinc Sulphate, which are highly toxic to exposed tissue. The Silver-Silver Chloride electrodes meet the demands of medical practice with their highly reproducible parameters and superior properties with regard to long term stability. Hence, these electrodes were chosen for signal acquisition [8].

The potential difference between electrodes can vary due to movement. This variation is known as Motion Artefact and causes interference in bio-potential measurements. For example, a wandering baseline (Figure 3) but otherwise normal signal is due to motion artefact. It is usually experienced right after electrodes have been applied or during patient movement and is due to a relatively slow establishment of electrochemical equilibrium at the electrode-skin interface. Poor contact between electrodes and the signal source can be another source of interference.

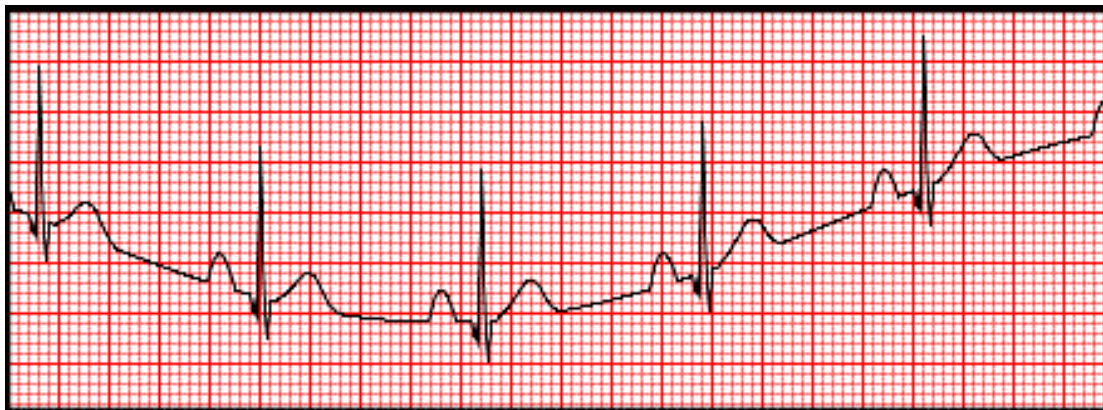

Fig. 3. ECG signal with baseline drift

3.2 Amplification and Signal Conditioning

A major challenge in the design of a system like this is acquiring and measuring very small electrical signals in the presence of much larger noise components. The typical ECG signal has amplitude between 1mV and 4mV. Although the average amplitude is only around 1 mV, there are large dc offset voltages due to electrochemical processes between the electrode/skin interfaces. These can be as high as 500 mV. The human body acts like the

midpoint of a capacitive divider between one or more power lines and ground. Thus, common-mode voltages as high as 1.5V, can be superimposed on the body. Eliminating this source of noise is one of the major tasks of an ECG amplifier. Fortunately, the ECG signals are differential signals while the power line voltages are common-mode, so the noise can be reduced with differential amplifiers [9, 10].

The first stage of the ECG circuit include instrumentation amplifier it is the most important part in the circuit it should provide high gain to amplify the weak of ECG signal and be able immunity the noise (common mode signal) and other signal in electromagnetic spectrum. which amplifies the small difference between the signals and suppresses the common-mode interferences at the two electrodes with a common-mode rejection function. The ECG sign appears as a differential potential between a pair of electrodes the two input terminals of the instrumentation amplifier. The interference signal appears as a common-mode potential on the two electrodes. The main task of the instrumentation amplifier is to select the desired signal from the interference to amplify by very high CMRR. Strong rejection of the common-mode signal is one of the most important characteristics of a good biopotential amplifier.

The AD624 is a high precision, low noise, instrumentation amplifier designed primarily for use with low level transducers, including load cells, strain gauges and pressure transducers. A combination of low noise, high gain accuracy, low gain temperature coefficient and high linearity make the AD624 ideal for use in high resolution data acquisition systems. The AD624C has an input offset voltage drift of less than $0.25 \mu\text{V}/^\circ\text{C}$, output offset voltage drift of less than $10 \mu\text{V}/^\circ\text{C}$, CMRR above 80 dB at unity gain (130 dB at $G = 500$) and a maximum nonlinearity of 0.001% at $G = 1$. In addition to these outstanding dc specifications, the AD624 exhibits superior ac performance as well. A 25 MHz gain bandwidth product, 5 V/ μs slew rate and 15 μs settling time permit the use of the AD624 in high speed data acquisition applications.

The AD624 as shown in figure 4 does not need any external components for trimmed gains of 1, 100, 200, 500 and 1000. Additional gains such as 250 and 333 can be programmed within one percent accuracy with external jumpers. A single external resistor can also be used to set the 624's gain to any value in the range of 1 to 10,000.

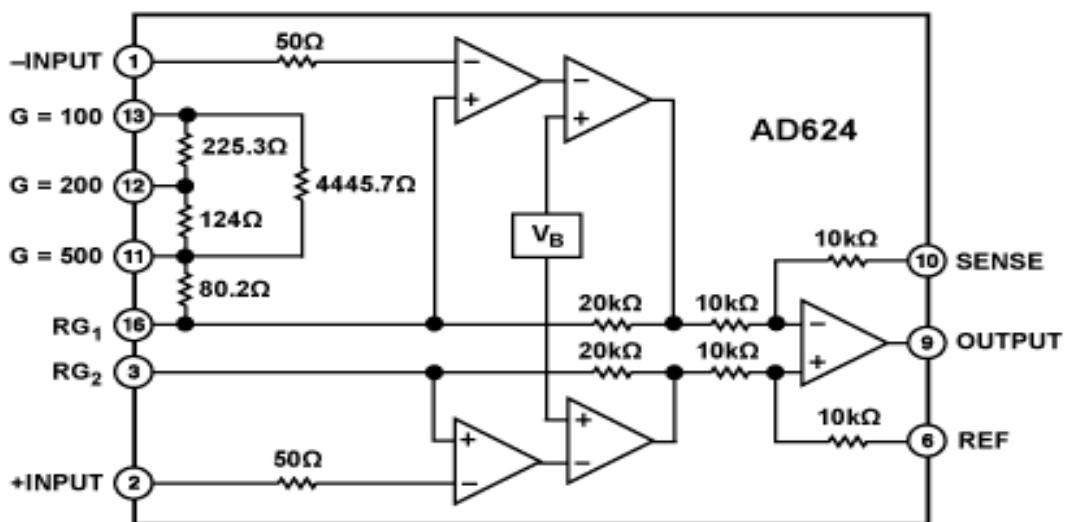

Fig. 4. Functional block diagram for AD624

The motivation of the right leg drive circuit is to reduce interference from the amplifier. It is possible to amplify an ECG signal and create a DC common mode bias electrically off the inputs of the differential amplifier. However, when this is done there is extreme susceptibility to common mode interference which is where the need for the right leg drive comes in. The right leg drive inverts and amplifies the average common mode signal back into the patient's right leg as shown in figure 5. The right leg driver is implemented in ECG measurement systems to counter common mode noise in the body. The two signals entering the differential amplifier are summed, inverted and amplified in the right leg driver before being fed back to an electrode attached to the right leg. The other electrodes pick up this signal and hence the noise is cancelled.

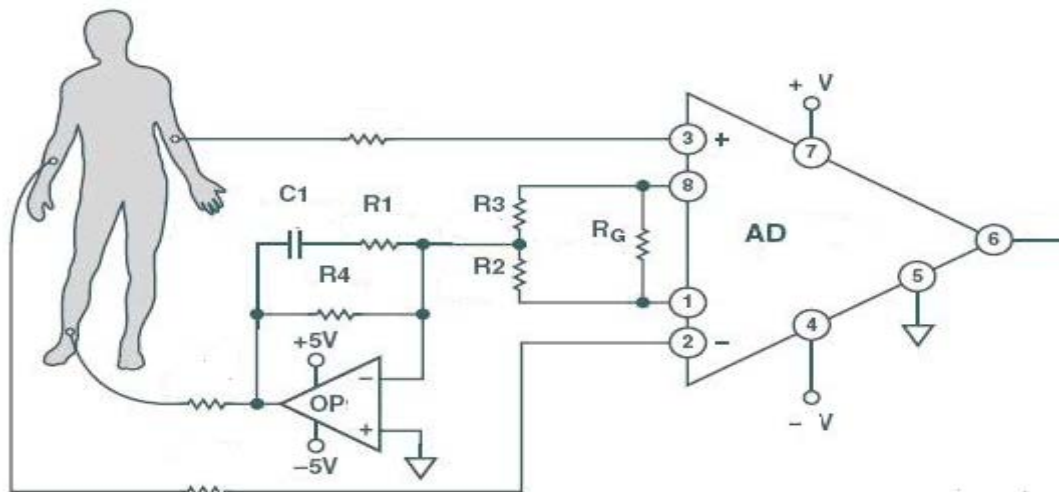

Fig. 5. Right Leg Drive circuit

The terms used to describe characterizes of a filter are defined as follow. The range of frequencies over which the output is significantly attenuated is called the stop-band. The frequency range over which there is little attenuation is called a pass-band. The frequency associated with the boundary between a pass-band and an adjacent stop-band is called the cut-off frequency. The most widely used approach defines the cut-off frequency as the frequency at which the gain has decreased by a factor of $1/\sqrt{2}=0.707$ from its maximum value in the pass-band. The bandwidth of a gain characteristic is defined as the frequency range spanned by its pass-band.

A filter is used to attenuate certain frequencies of a signal. The attenuation level depends on the type of filter used. For this circuit, we use two active RC filters. A high pass filter with cut-off frequency of 0.5Hz is placed between the pre-amplification and low pass filter. The purpose of this filter is to reduce DC offset form being amplified with the signal and amplifier saturation. A low pass filter was placed at the output of the high pass filter to attenuate high frequency noise above 130Hz.

Actually we use dc offset as shown in figure 6 because some component of (QRSTU) waves in negative portion so if we want to convert our signal to digital form we need to make dc offset or we can use bi polar analog to digital converter.

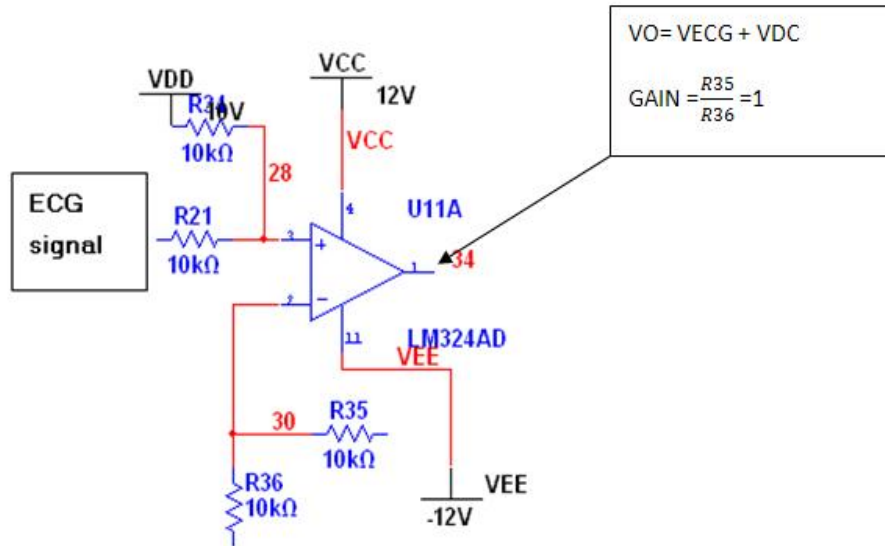

Fig. 6. DC offset circuit

3.3 Power Supply Unit

The main power supply of the proposed system as shown in figure 7 is a simplified design to give output 12VDC,-12VDC to supply analog parts and 5VDC to supply digital parts. A voltage regulator can be used to guarantee the required voltage supply to the microcontroller other peripherals and components. An integrated circuit regulator (LM8705, LM7812 and LM7912) is used in the power supply unit to maintain the level of the required voltage in the most units in the proposed ECG.

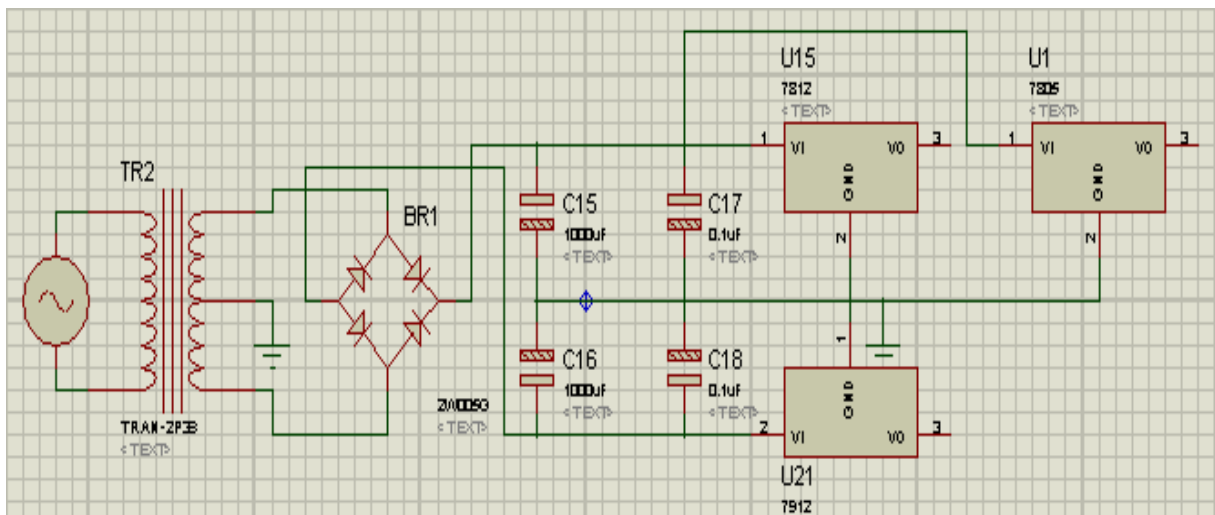

Fig. 7. Schematic of a power supply unit

3.4 MCU and DAC

Microcontrollers provide many benefits to our lives, including the ability to make many of the products we use more energy efficient. Central heating and air conditioning units is one area where microcontrollers are used to make motors run more efficiently or to provide higher quality regulation and more enhanced user interfaces on thermostats. When building a microcontroller based thermostat, some of the important goals include small size, low power, low cost, high reliability, and easy manufacturability. One of the ways to reach these goals is to use a highly-integrated microcontroller that supports features directly applicable to building a thermostat. The microcontroller ATMEL Atmega32 is used because this product has already build-in analog to digital converter that is needed in this project .it is means that no need to construct another analog to digital converter circuit.

The resolution of the converter indicates the number of discrete values it can produce over the range of Analogue values. The values are usually stored electronically in binary form, so the resolution is usually expressed in bits. In consequence, the number of discrete values available, or "levels", is usually a power of two. For example, an ADC with a resolution of 8 bits can encode an Analogue input to one in 256 different levels, since $2^8 = 256$. The values can represent the ranges from 0 to 255 (i.e. unsigned integer) or from -128 to 127 (i.e. signed integer), depending on the application. Resolution can also be defined electrically, and expressed in volts. The voltage resolution of an ADC is equal to its overall voltage measurement range divided by the number of discrete intervals

3.5 Serial Communication

Digital devices can communicate with each other using logic. This binary information is organized into groups. Each binary digit in these groups is called a bit. The larger the group is, the more information is sent at one time. A 64 bit game system has better graphics than a 32 bit game system, since there is much more information in 64 bits. This allows the computer to draw a more accurate picture. It is very common to see serial communication in 8 bit groups called bytes. Serial communication works by sending one byte of information after another through one wire and a ground. The ECG uses a serial communication format called RS-232 as shown in figure 8. This is the format used by all serial ports on IBM PC's as well as many other devices. The main difference between normal serial communication and the RS232 format is that the normal voltage range for TTL is +5 to 0 VDC; the voltage range of the RS-232 format has been increased to +10 to -10 VDC. The ECG uses the MAX232 IC to convert the serial data from the microprocessor to the RS-232 format.

3.6 Software Design

The software is divided between on-board software for the slave nodes that manages the analog-digital conversion and sending of the data, and PC software responsible for receiving the data and displaying the signal.

The ECG signal's bandwidth is 100Hz, so according with the Nyquist's theorem; the minimum required sampling frequency is 200Hz. The program is sampling with at 250Hz which is a sufficiently large frequency for acquiring the ECG signal. The cross compiler that used to develop the embedded program for the proposed ECG is a mikroC PRO for AVR IDE (Integrated Development Environment) which is dedicated for ATMEL AVR family of microcontroller. A Tmega32 micro-controller is used to manage the digitization of the ECG signals by built in 10-bit A/D converter and Atmega's USART used to communicate data to the PC for showing.

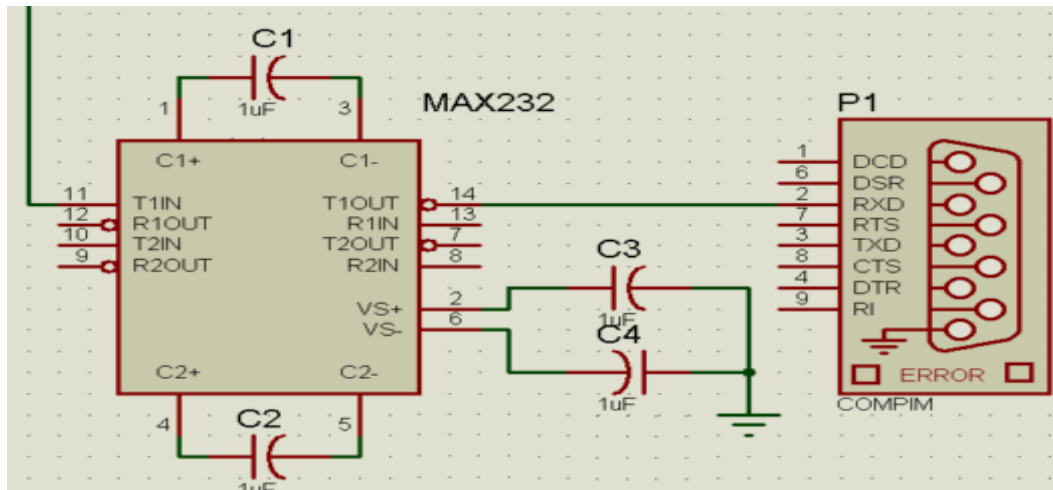

Fig. 8. Schematic of MAX232 with Female serial Connector

In a PC side the Graphical User Interface (GUI) as shown in figure 9 is designed using LabVIEW™ to communication between the standard PC/laptop and the proposed ECG circuit to store the ECG signal values in a MS data base file in a PC. Lab VIEW™ (Laboratory Virtual Instrument Engineering Workbench) is a software package developed to build programs with symbols (icons) rather than writing out lines and lines of programming text. It uses symbols, terminology and formats that are familiar to technicians, scientists, and engineers. LabVIEW™ is programmed to act as an interface, helping pieces of hardware “communicate” with each other. Moreover, LabVIEW™ offers built-in libraries that allow the user to work over the internet and use different programming formats and systems.

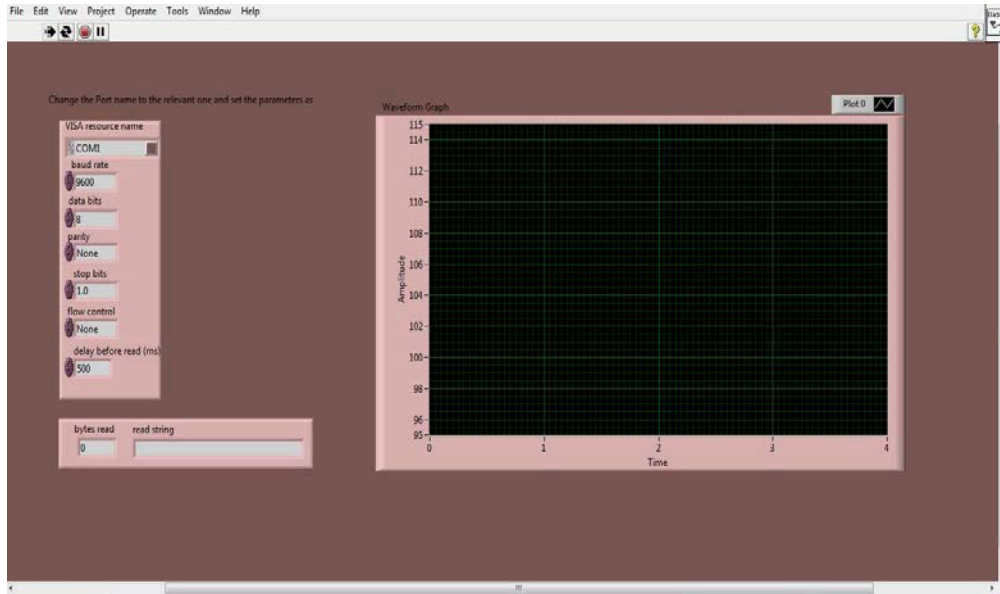

Fig. 9. Designed of labview GUI

4. Result and Discussion

Successful implementation of the hardware necessary to obtain an ECG signal with a right leg driver is evidenced in the overall results where a clean ECG signal is obtained and displayed on PC Provider by LabVIEW™. All the hardware is implemented on a small PCB as shown in Figure 10.

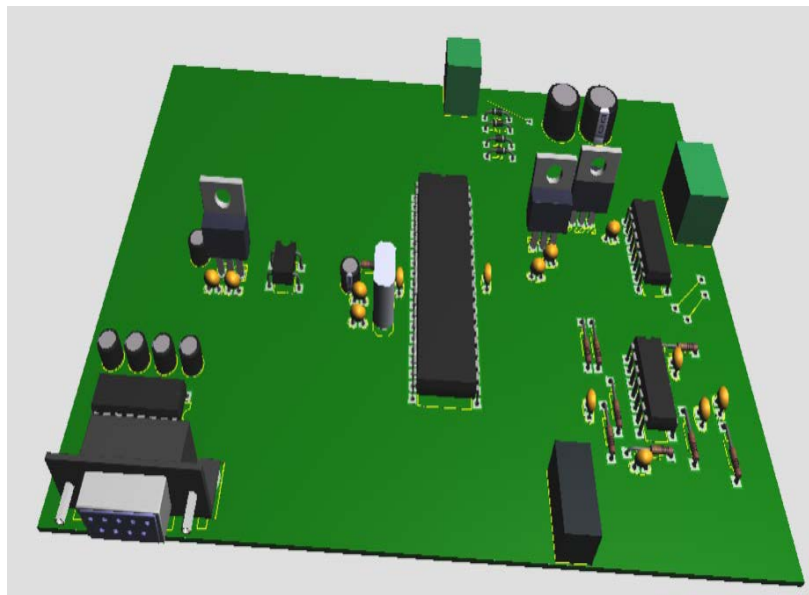

Fig. 10 Hardware PCB

This project involves the Interaction with biological signals, which in general, would involve an actual human connection for data acquisition. In order to test appropriately, there was need for some simulated bio-signals to

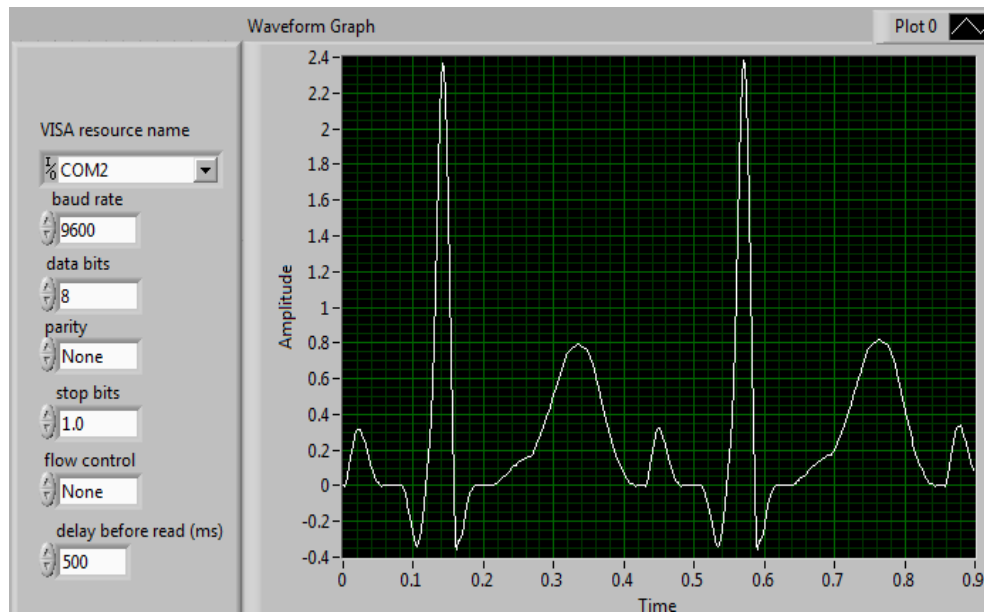

Fig. 13 the received ECG through a GUI

5. Conclusion

To conclude this project, the main objective has been achieved as a satisfactory level. The goal of this project is to design a PC Based ECG that will provide an accurate reading of ECG signal from patient and display this signal in PC through LABVIEW VI. Good results are achieved despite the simplicity of the electronic hardware used.

The current state of the project should not be looked at, as a final product, but merely as a promising platform by which to maintain enhancements within the design. With a continuation of the current design, the proposed end product is very realistic and attainable. There are some design limitations such as: high power consumption that inherit from component utilize in design, which can be reduced by utilize the good components, as well as this design hasn't include a notch filter to eliminate the power line noise.

References

- [1] M. Lu, "the Design and Construction of an ECG Telemetry System." M.Sc. Thesis, University of Queensland, 1994
- [2] WEBSTER J.G. (1998) Medical Instrumentation – Application and Design (John Wiley & Sons, New York, USA) 3rd Edition
- [3] ROBERT M. B. and MATTHEW N.L. (1991) Cardiovascular Physiology (Mosby –Year Book, Missouri, USA) 6th Edition
- [4] WOOD D. E., EWINS D. J., and BALACHANDRAN W. (1995) 'Comparative analysis of power-line interference between two- or three-electrode biopotential amplifiers'

- [5] Fye WB. "A history of the origin, evolution, and impact of electrocardiography". Am J Cardiol 1994.
- [6] Snellen HA. Willem Einthoven (1860-1927) Father of electrocardiography. Kluwer Academic Publishers, Dordrecht: 1995.
- [7] Kerry Lacanette, A Basic Introduction to Filters – Active, Passive, and Switched Capacitor, National Semiconductor Application note April 1991
- [8] R.S. Khandpur. Biomedical Instrumentation: Technology and Applications, McGraw-Hill Companies, Inc., 2005.
- [9] T. Kugelstadt. "Getting the Most Out of Your Instrumentation Amplifier Design". Analog Applications Journal, 2005.
- [10] W. Grossbach. "Measuring the ECG Signal with a Mixed Analog-Digital Application-Specific IC", Hewlett-Packard Journal, 1991
- [11] Compiler, WinAVR, and Joe Pardue. "C Programming for Microcontrollers." (2005).
- [12] Wood D. E., EWINS D. J., and BALACHANDRAN W. (1995) 'Comparative analysis of power-line interference between two- or three-electrode biopotential amplifiers' Med. & Biol. Eng. & Comp., Jan. 1995