



Incremental Learning Approach for Enhancing the Performance of Multi-Layer Perceptron for Determining the Stock Trend

Basant Ali Sayed Ali^{a*}, Abeer Badr El Din Ahmed^b, Alaa El Din Muhammad El Ghazali^c, Vishal Jain^d

^a*Teaching of Department of Management Information System , Higher Institute of Qualitative Studies, Cairo, Egypt*

^b*Lecture of Department Computer Science , Sadat Academy for Management Sciences, Cairo, Egypt*

^c*Professor of Department Computer and Information system ,Sadat Academy for Management Sciences, Cairo, Egypt*

^d*Assistant Professor of Department Computer Applications and Management, Bharati Vidyapeeth's Institute of Computer Applications and Management, New Delhi, INDIA*

^a*phd_basant@yahoo.com*

^b*abadredin@hotmail.com*

^d*vishaljain83@ymail.com*

Abstract

This paper introduces a new technique for achieving minimum risk of predicting stock trend using multi-layer perceptron. The proposed technique presents the method of classification the stock trend .the paper show a comparison among multi-layer perceptron, gene learning theory. The achieved results show the superior performance of the multi-layer perceptron which is based on mathematical back ground.

Keywords: Prediction, Multi-layer Perceptron, Grid search, classification accuracy.

* Corresponding author.

E-mail address: phd_basant@yahoo.com

1. Introduction

It is sure that the main challenge to discover the technique of Stock market prediction is an applicable and less complicated application of machine learning algorithms. It is found that many various effort in price prediction by using methods such as Neural Network, Linear Regression(LR), Multi Linear Regression(MLR), Auto Regressive Moving Average Models (ARMA) and Genetic Algorithms(GA) .In this report we consider about the Twin Gaussian Process (TGP) method to predict the stock prices. Because of dynamic manner of stock market prices, prediction is so difficult. Increase and decrease of stock market prices depends on various factors such as amount of demand, exchange rate, price of gold, price of oil, political and economic events and ... but in the other view point we can consider the stock market price variation as time series and without notation to the mentioned factors, and just by finding the sequence rules of price train, make the price prediction in the future. There are so many researches in price variation time series prediction by different methods such as Neural Network, LR, MLR; ARMA, GA. Neural Network is one of the popular methods for predicating stock market. Most of researches that use Neural Network for prediction, use Multi-Layer Perceptron and use back propagation for learn Network. Who Train Neural Network by historical data of stock for predicting price in future.

2. Limitations of the research

- The paper focus on the binary classification process performed by neural network.
- The domain of the application is the Egyptian stock market.
- The selected sector of the Egyptian stock market is textile sector.
- The results achieved under the normal economic conditions of the Egyptian stock market.

3. Adaptive Activation Functions

There is a method for improving the performance of the neural network based on enabling the functions of the activation to modify related to the training data characteristics obtained. Using the adaptive activations functions is considered one of the earlier methods which are developed by Zurada. In this case the achieved slope of the selected sigmoid activation function can be learned simultaneously by the achieved weights. In this case the slope parameter λ is gained for every output and hidden layers. Furthermore there is an Additional development is achieved by Engel Brecht et al for the lambda-learning algorithm. Here, the definition of this sigmoid function can be shown as

$$f(net, \lambda, \gamma) = \frac{\gamma}{1 + e^{-\lambda net}}$$

Such λ is defined as the slope of the function and γ is considered the maximum range. There is an additional development is achieved by Engel Brecht et al for learning equations to can learn the maximum ranges of the used sigmoid functions, thereby doing automatic scaling process which is based on gamma-learning. This development has no need to scale target values to the range (0, 1). The result of modifying the slope and range of the sigmoid function which is called delta learning, the lambda and variations of gamma learning,

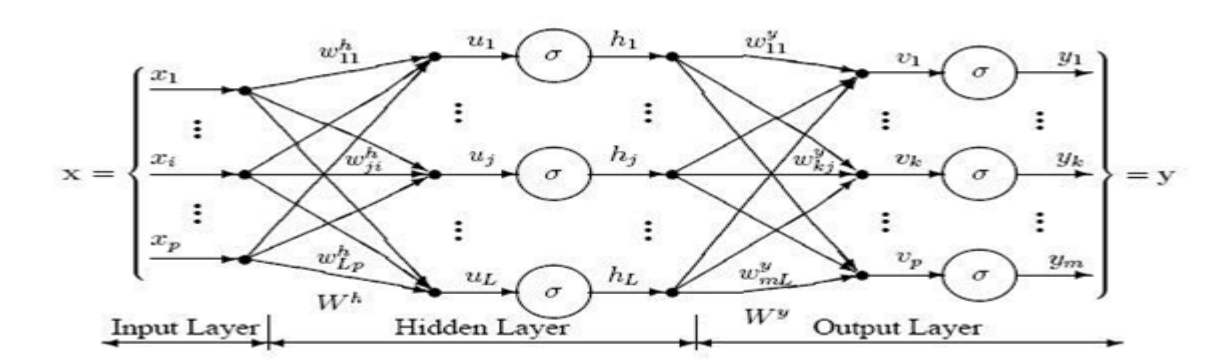

Fig 1: the Multi-layer perceptron structure

4. Challenges for the Training Multilayer Perceptron Networks

The main aim of the training process is discovering the group of weight values that will make the output from the neural network can match the actual target values as closely as possible [2].

No doubt that there are many critical points that involved in designing and training a multilayer perceptron network:

- Selecting how many hidden layers to use in the network.
- Deciding how many neurons to use in each hidden layer.
- Finding a globally optimal solution that avoids local minima.
- Converging to an optimal solution in a reasonable period of time.
- Validating the neural network to test for over fitting.

5. Neural network Model Experiments:

4.1. Selective Learning

Not much research has been done in selective learning. Hunt and Deller developed Selective Updating, where training starts on an initial candidate training set. Patterns that exhibit a high influence on weights, i.e. patterns that cause the largest changes in weight values [3].are selected from the candidate set and added to the training set. Patterns that have a high influence on weights are selected at each epoch by calculating the effect that patterns have on weight estimates. These calculations are based on matrix perturbation theory[5].Where an input pattern is viewed as a perturbation of previous patterns.If the perturbation is expected to cause large changes to weights, the corresponding pattern is included in the training set. The learning algorithm does use current knowledge to select the next training subset, and training subsets may differ from epoch to epoch [9]. Selective Updating has the drawback of assuming uncorrelated input units, which is often not the case for practical applications.

4.2. Incremental learning

Research on incremental learning is more abundant than for selective learning. Most current incremental learning

Techniques have their roots in information theory, adapting Fedorov's optimal experiment design for NN learning[12]. The different information theoretic incremental learning algorithms are very similar, and differ only in whether they consider only bias, only variance, or both bias and variance terms in their selection criteria. One drawback of the incremental learning algorithms summarized above is that they rely on the inversion of an information matrix [7]. Fukumizu showed that, in relation to pattern selection to minimize the expected MSE, the Fisher information matrix maybe singular.

4.3. Converging to the Optimal Solution – Conjugate Gradient

It is a set of starting weights value where that selected randomly. The suggested approach use the benefits generated from the conjugate gradient technique. Practically, majority of training algorithms are based on similar cycle to select the best values of weights. Firstly, run the values predicted for the case through the selected network based on tentative set of weights [15]. Secondly, calculate the variation among the target predicted and the actual target for the case. This is called the error of the prediction .thirdly; calculate the mean error of the information through the set of training cases. 4. Generate the achieved error backward by the network itself and calculate the gradient (vector of derivatives) of the difference in the achieved error with respect to difference in the values of weight 5 [6]. Perform the current adjustments to the generated weights to reduce the error. Every cycle of this is called a /epoch/. Due to the generated error information is propagated backward by the network, this sort of training technique is called /backward propagation/ or "back prop". The fundamental technique is based on using the /gradient descent/ algorithm to modify the value weights to can convergence based on the gradient [8]. Majority of neural networks use the best of algorithm .this approach can provide the classical conjugate gradient algorithm with line search, but it also offers a newer algorithm, /Scaled Conjugate/ /Gradient/ (see Moller, 1993). This technique is based on using the technique of numerical approximation for the second derivatives that be called Hessian matrix). On the other hand in the same time, it can avoid instability by combining the model-trust region technique from the Liebenberg-Marquardt technique with the conjugate gradient approach. This permit the scaled conjugate gradient to calculate [3] .what is the optimal step size in the search direction without having to done more expensive computations in line search used by the classical conjugate gradient algorithm. It is sure, that must be a cost involved in evaluating the second derivatives [5]. The performed Tests by Moller show the scaled conjugate gradient algorithm converging up to approximately twice as fast as classical conjugate gradient and up to twenty times as fast as the neural back propagation which is based on gradient descent. Moller's tests also presented that scaled conjugate gradient failed to converge less often than traditional conjugate gradient or back propagation using gradient descent [4].

4.4. The approach for Avoiding Over fitting

Over fitting case “happens only when the parameters of a model are trained so tightly that the model fits the training data well but has poor accuracy on separate data not used for training. Especially the type of network is called Multilayer perceptron's are subject to over fitting as are most other types of models. The paper has a

method for dealing with over fitting by selecting the optimal number of neurons. The paper has a method for dealing with over fitting: (1) by selecting the optimal number of neurons as described above, and (2) by evaluating the model as the parameters are being tuned and stopping the tuning when over fitting is detected. This is known as “early stopping”.

6. The proposed algorithm

The best neural network structure was chosen from Table (1) below. The selected network has 5 input neurons with 11 hidden neurons and 1 output.

Each MLP in Table (1) was trained and tested using different learning rates and epochs. The best network (marked in bold font) was chosen using the least difference between the training and testing data. The motivation for using this criterion is to ensure that the network chosen can predict the stock price as accurate as possible.

The proposed algorithm

- 1- Prepare the data collected.
- 2- Clean the data.
- 3- Run the model of neural network optimized by grid search.
- 4- Compute the relative importance of dimensions.
- 5- Rank the relative importance of dimensions.
- 6- Select Best dimensions achieving minimum error.
- 7- If the minimum errors satisfy acceptable error, stop or else go to step 3.

7. Experiments and results

This subsection shows a comparison between neural network and hybrid neural and grid search

Input Data

Input data file: \csv\bolivar.csv

Number of variables (data columns): 47

Data subletting: Use all data rows

Number of data rows: 800

Total weight for all rows: 800

Rows with missing target or weight values: 0

Rows with missing predictor values: 1

6.1. Neural Network Parameters

Number of rows excluded because of missing predictor values = 1

Table1: shows the Neural Network Architecture

Layer	Neurons	Activation	Min. Weight	Max. Weight
Input	5	Passthru		
Hidden1	13	Linear	-1.483e+000	1.706e+000
Output	3	Linear	-1.787e+000	1.516e+000

Table2: shows Category weights (prior probabilities)

Category	Probability
Down	0.5225564
Up	0.4398496
stable	0.0375940

6.1.2. Training Statistics

Table3: shows error generated by Conjugate gradient

Process	Time	Evaluations	Error
Conjugate gradient	00:00:02.5	806,145	9.5403e-002

6.1.3. Model Size Summary Report

Network size evaluation was performed using 4-fold cross-validation.

Table 4: shows Network size evaluation was performed using 4-fold cross-validation

Hidden layer 1 Neurons	MLP % Misclassifications	IncrementalMLP % Misclassifications
2	42.765433221	37.09273
3	38.67765442	32.20551
4	35.675576	32.83208
5	34.87656578	32.08020
6	34.9876543	32.08020
7	33.86664532	32.58145
8	34.87675445	33.33333
9	34.97776654	31.95489
10	38.677788	34.58647
11	38.8766554	33.83459

12	34.678909087	32.08020
13	33.78769<-- Optimal size	31.82957 <-- Optimal size
14	35.77654678785	32.08020
15	34.865543489	33.45865
16	34.0324566	32.95739
17	34.0876543	32.95739
18	35.7766554	33.45865
19	35.94567870	33.45865
20	36.876554443	33.70927

The network will be built using 13 neurons for hidden layer 1.

6.1.4. Misclassification Tables

6.1.4.1. Training Data

Table 5: shows the error training of Misclassified data

Category	Actual		Misclassified			
	Count	Weight	Count	Weight	Percent	Cost
Down	417	417	60	60	14.388	0.144
Stable	30	30	30	30	100.000	1.000
UP	350	350	159	159	45.429	0.454
Total	797	797	249	249	31.242	0.312

Overall accuracy = 68.76%

6.1.4.2. Validation Data

Table 6: shows the error validation of Misclassified data

Category	Actual		Misclassified			
	Count	Weight	Count	Weight	Percent	Cost
Down	417	417	61	61	14.628	0.146
Stable	30	30	30	30	100.000	1.000
UP	351	351	153	153	43.590	0.436
Total	798	798	244	244	30.576	0.306

Overall accuracy = 69.42%

6.1.5. Confusion Matrix

Training Data Validation Data

Table 7: shows confusion matrix in training process Table 8: shows confusion matrix in validation process

Actual	Predicted Category		
Category	Down	Stable	Up
Down	357	0	60
Stable	22	0	8
Up	159	0	191

Actual	Predicted Category		
Category	Down	Stable	Up
Down	356	0	61
Stable	22	0	8
Up	153	0	198

8. Discussion & conclusion

No one can deny that it has been one of the greatest challenges to predict the stock market next change. However, stock prices have dramatically change , it is an essential need to find an answer to the question of when to buy and sell and forecast the future price of a stock to achieve the main goal of high returns and minimize dramatic losses .

The proposed system uses the efficient techniques of artificial intelligence support vector machines, neural network, and Gene Expression programming. strategies that are used for analytical purposes is accuracy of the classification .this strategy allow forecasting future price changes, and help decision maker to take successful decisions. The proposed system are based on mathematical considerations for some characteristics such as price & volumes to generate forecasting which indicate the idle time to open or close positions.

Reference

- [1] C.M. Bishop. *Pattern Recognition and Machine Learning* ,Springer, 2007.
- [2] O. Chapelle. *Training a support vector machine in the primal*.In L. Bottou, O. Chapelle, D. DeCoste, and J. Weston, editors, *Large Scale Kernel Machines*, MIT Press, Cambridge, MA., 2007.
- [3] Chen, Y., Dong, X., & Zhao, Y. (2005). "Stock index modeling using EDA based local linear wavelet neural network". *Proceedings of International Conference on Neural Networks and Brain*, 1646–1650.
- [4] Chih-Wei Hsu, Chih-Chung Chang, and Chih-Jen Lin."A practical guide to support vector classification.Technical report, Department of Computer Science", *National Taiwan University*, 2003.
- [5] C. Cortes and V. Vapnik."Support vector networks". *Machine Learning*, 20:273{297, 1995.

- [6] N. Cristianini and J. Shawe-Taylor. *An Introduction to Support Vector Machines*. Cambridge UP, Cambridge, UK, 2000.
- [7] T. Hastie, R. Tibshirani, and J.H. Friedman. *The Elements of Statistical Learning*. Springer, 2001.
- [8] W.S. Noble. “What is a support vector machine? Nature Biotechnology”, 24(12):1564{1567, 2006.
- [9] Olson, D., & Mossman, C. (2003) .” Neural network forecasts of Canadian stock returns using accounting ratios” .*International Journal of Forecasting*, 19(3), 453–466.
- [10] F. Provost. “Learning with imbalanced data sets 101”, *In AAAI 2000 workshop on imbalanced data sets*, 2000.
- [11] J. Shawe-Taylor and N. Cristianini. *Kernel Methods for Pattern Analysis*. Cambridge UP, Cambridge
- [12] B. Scholkopf, and A. Smola .*Learning with Kernels*, MIT Press, Cambridge, MA , 2002. .
- [13] B. Scholkopf, K. Tsuda, and J.P. Vert, editors. *Kernel Methods in Computational Biology*, MIT Press series on Computational Molecular Biology, MIT Press, 2004.
- [14] S. Sonnenburg, M.L. Braun, C.S. Ong, L. Bengio, S. Bottou, G. Holmes, Y. LeCun, K Muller, F Pereira, C.E. Rasmussen, G. Ratsch, B. Scholkopf, A. Smola, P. Vincent, J. Weston, and R.C. Williamson . “The need for open source software in machine learning”. *Journal of Machine Learning Research*. 8:2443{2466, 2007.
- [15] Thawornwong, S, & Enke, D. (2004). “ The adaptive selection of financial and economic variables for use with artificial neural networks”. *Neurocomputing*, 56, 205–232.
- [16] AbeerBadr El Din ,Basant Ali. “Predicting the Stock Trend by Artificial Intelligence Techniques based on Structural Risk Minimization”. *International Journal of Advanced Research in Computer Science and Software Engineering* . Volume 3, Issue 11, November 2013; 1342- 1347.
- [17] AbeerBadr El Din ,Basant Ali . “Hybridization between Grid Search and Support Vector Machines for Predicting Stock Trend”. *International Journal of Advanced Research in Computer Science and Software Engineering* . Volume 3, Issue 12, December 2013; 808-813.