



International Journal of Sciences: Basic and Applied Research (IJSBAR)

ISSN 2307-4531
(Print & Online)

<http://gssrr.org/index.php?journal=JournalOfBasicAndApplied>



Genetic –Morphological Approach to Creating Wide Range Drilling-Milling Chucks

Juriy Nikolayevitch Kuznetsov^a, Hasan Al-Dabbas^{b*}, Hamyela Guerra^c

^a National Technical University of the Ukraine “Kiev Politechnical Institute” (Ukraine)

^b Philadelphia University (Jordan)

^c National Technical University of the Ukraine “Kiev Politechnical Institute”

^azmok@mail.com

^bhaldabbas@ Philadelphia.edu.jo

Abstract

The problem about creating new technical systems can be successfully solved in modern science by using a new methodological approach which includes systematic analysis, principles of evolution, morphological analysis, and other methods for searching technical solutions. This article deals with the synthesis of wide range drilling-milling chucks by new approach.

Keywords: genetic-morphological approach; clamping chuck; forcing (emerging) steam; technical system.

1. Introduction

Providing the required clamping force of the clamping mechanism is now a necessary condition but is not sufficient, due to the increased flexibility of quickset automated production which requires wide-bandness and quick regulating of the clamping mechanisms, in particular, chuck engineering or chucks (CE), while maintaining the accuracy, rigidity, durability and stability characteristics [6,21,22,24,26].

This article analyses the influence of the CE structure on their wide-bandness and quickset while changing the diametrical size of the object clamp (OC), which may be a cylindrical shank cutting tools (drills, mills, etc.), rod or piece-blank [6,21,22,25].

According to the systematic approach, within a huge variety of the CE construct the quantity of their structures is limited by the direction of the input force from the power source and the drive clamp with the help of the method of energy conversion and transmission of power flow into the CE, the CE power circuit, which can be closed and (or) broken, open, and (or) closed due to the closing of the clamping force, and the connections to the power source and drive clamp [2,6,9,21].

* Corresponding author.

E-mail address: haldabbas@ Philadelphia.edu.jo

The systematic approach allows to combine the structural studies in science and technology successfully because of its interdisciplinary nature, using appropriate philosophical categories and general theory of systems regulations [18,20].

2. Exposition

The object lesson of interdisciplinary and community systems approach can be the theory of evolution transfer of electromechanical systems [15] into mechanical and other systems [1,7,14].

A new approach to the development of structural and systemic explore the TC by creating a clamping mechanism (ZM). This approach involves the use of genetic and morphological HEREUNDER, wherein in the genetic structure of ZM from genetic (mechanical) gene and chromosomal (parental chromosome) levels is complicated, forming of the respective chromosomes of derived first, second, ..., n-th generation.

3. Root of the matter

In the design of the clamping mechanisms (ZM) as a vehicle may address the following engineering tasks (Table 1) [13,20]: 1 - find a new way of clamping; 2 - Create a new ZM, 3 - a new use for ZM, 4 - ZM modernization; 5 - Improvement of ZM and the way the clip.

Table 1

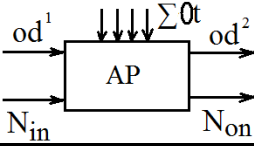
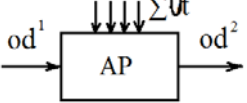
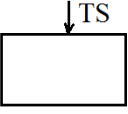
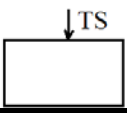
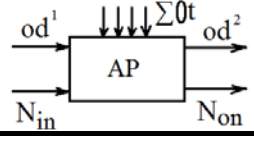
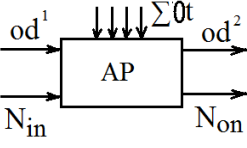
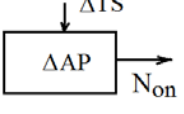
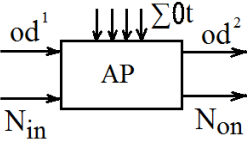
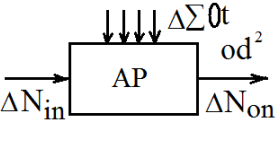
No task	Situation	Given	Find	Activities
1	To meet the requirements we need a new way of clamping			The design process for a given output
2	For a given operand, the way the clip and all operators of existing TS			Create (choice) of a new TS (CM)
3	Developed for the possibility of using the existing TS			A new application of existing TS (CM)
4	Output side of the existing TS harmful			The development (modernization) TS (CM) liquidation side exit
5	Necessary to increase the efficiency of TS and the method of clamping			Improving TS (CM), and how the clip

In Table 1, the following notation: od^1 - the initial state of the operand at the input; od^2 - a necessary end state operand at the output; N_{in} - side inputs (unbalanced centrifugal force units) N_{on} - side-outs (loss of clamping force); TS -

technical system ; AP - workflow (clamp method); ΣOt - operators (worker exposure in the form of forces and moments, cutting hardware (ZM), the environment - the external impact on the ZM; ΔTS - deviation parameters of the TC (ZM); ΔAP - deviation of workflow options (clamp method); ΔNin - deviation of side entrances; ΔNon - deviation of side exits.

Creating a new vehicle due to the solution of the problem number 2, you start with the genetic level. In genetics, the term denotes a gene material medium, created by nature, by which the transmission of hereditary information in a number of generations [1,10,11,15,18].

This definition and wave processes [9] elementary mechanical structures of natural origin - energy intensive power flow, distributed at a certain speed from the source through the power converters to secure the object and create a contact clamping element - the object of securing the state of stress [2,8,9].

If the electro-mechanical systems, electromagnetic genome is a basic source of the electromagnetic field (moving charge, microstructure Ampere) [15], in any mechanical systems mechanical genome is a basic source of energy (power) of the field, which can serve as a point mass [8,14,19], moving in the space under the force F or torque shoulder r , $M = Fr$, (Fig. 1a). In a Cartesian coordinate system XYZ (Fig. 1b) can be sources of traffic $F \in$ three forces F_x, F_y, F_z , and three of the torque $M \in M_x, M_y, M_z$, where:

$$M_x = F_y \cdot r_z = F_z \cdot r_y,$$

$$M_y = F_x \cdot r_z = F_z \cdot r_x,$$

$$M_z = F_x \cdot r_y = F_y \cdot r_x.$$

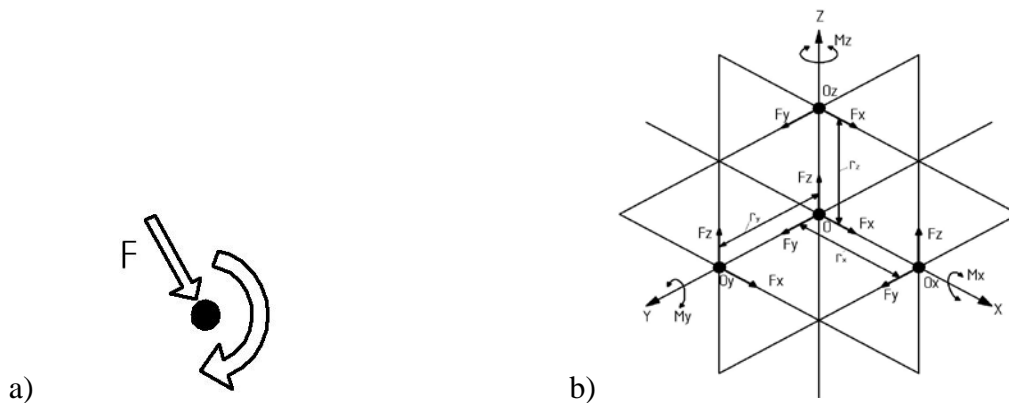

Figure 1. Mechanical gene - a moving material point

Transfer of energy from a single point on one input to another material outlet point 2 (Fig. 2) is possible through the energy converter, which may be mechanical, hydraulic, pneumatic rotary, solenoid, etc.

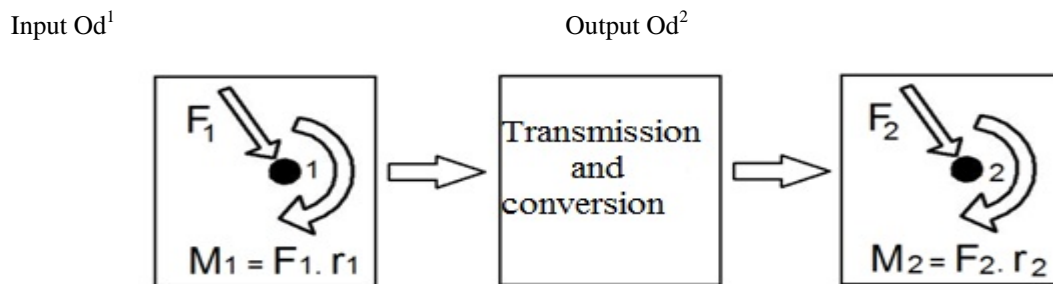

Figure 2. Transfer Scheme and the conversion of energy between the two material points 1 and 2

The transfer of energy in the pronstranstve can be expressed as a power (energy) flow from the coordinate system to another $X1Y1Z1 X2Y2Z2$ (Fig. 3):

$$M_{EN} = \begin{pmatrix} \pm F_{x1} \\ \pm F_{y1} \\ \pm F_{z1} \\ \pm M_{x1} \\ \pm M_{y1} \\ \pm M_{z1} \end{pmatrix} \Rightarrow M_{EX} = \begin{pmatrix} \pm F_{x2} \\ \pm F_{y2} \\ \pm F_{z2} \\ \pm M_{x2} \\ \pm M_{y2} \\ \pm M_{z2} \end{pmatrix} \quad (1)$$

Where M_{EN} - matrix input; M_{EX} - matrix output

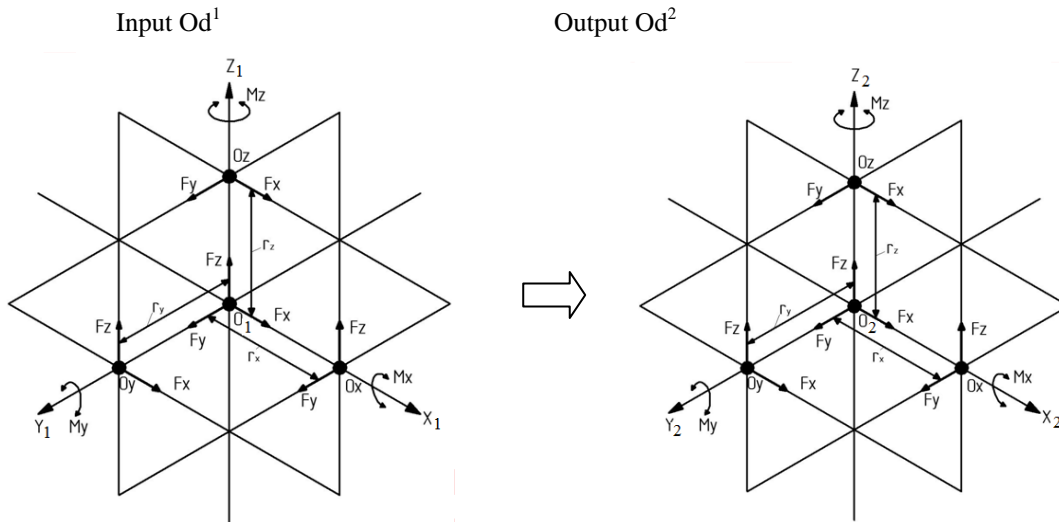

Figure 3. A generalized model of power (energy) flows

With regard to the principle of symmetry [11] and the evolution of mechanical systems [3,6] of all the power (energy) flows in one input and one output would be: $N_{sp} = 12 \cdot 12 = 144$. When clamping parts such as bodies of rotation of power flow is reduced to $N'_{sp} \cdot 4 = 8 = 32$ [9,16].

$$M'_{EN} = \begin{pmatrix} \pm F_{x1} \\ \pm F_{y1} \\ \pm M_{x1} \\ \pm M_{y1} \end{pmatrix} \Rightarrow M'_{EX} = \begin{pmatrix} \pm F_{x2} \\ \pm F_{y2} \end{pmatrix} \quad (2)$$

The conversion of energy in the power (energy) flow may be different converters, which are mechanical ispolnenii reduced to a limited number, and may include the following (Fig. 4): a - Lever (LV), b-wedge (WD), in - Spiral (SL) g - Screw (SC), d - spring (SR). The circuit implementation of power flow in either a simple mechanism with a transducer to the object level can be represented as a morphological model (Table 2).

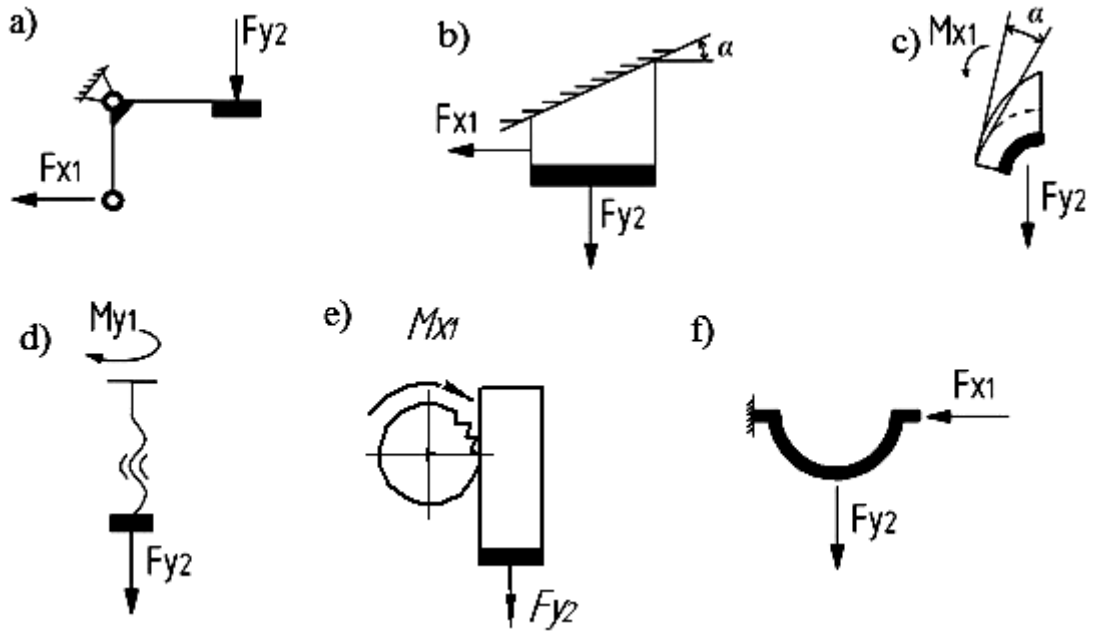

Figure 4. Mechanical energy converters: a - level (LV); b - wedge (WD); c - spiral (SP); d - screw (SC); e - gear (GR); f - spring (SR)

Table 2

Input Od ¹	Converter	Output Od ²
1.1. + F_{x1}	2.1. LV	3.1. + F_{x2}
1.2. - F_{x1}	2.2. WD	3.2. - F_{x2}
1.3. + F_{y1}	2.3. SL	3.3. + F_{y2}
1.4. - F_{y1}	2.4. SC	3.4. - F_{y2}
1.5. + F_{z1}	2.5. GR	3.5. + F_{z2}
1.6. - F_{z1}	2.6. SR	3.6. - F_{z2}
1.7. + M_{x1}		3.7. + M_{x2}
1.8. - M_{x1}		3.8. - M_{x2}
1.9. + M_{y1}		3.9. + M_{y2}
1.10. - M_{y1}		3.10. - M_{y2}
1.11. + M_{z1}		3.11. + M_{z2}
1.12. - M_{z1}		3.12. - M_{z2}

Total of different schemes will be: $N_{cx} = 12 \cdot 6 \cdot 12 = 864$.

Bodies of rotation, which can be clamped on the geometric shape are divided into thin discs or plates (FL), a prism (PR), the pyramids (PM), a cylinder (CL), the cones (CN), areas (AR) and the tori (TR).

Object-level the structure of the genetic formula "chuck - to clamp" (without a specific source of energy and drive) next (Fig. 5):

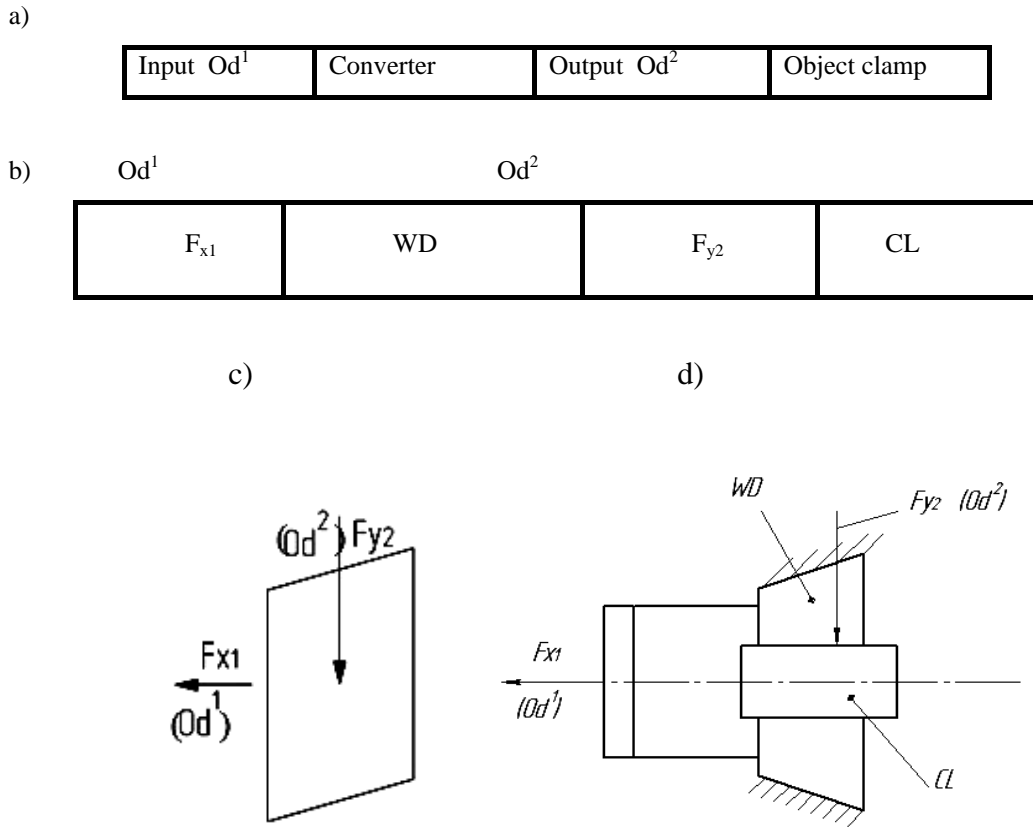

Fig. 5. The generalized structure of (a), a particular genetic formula (b), a power flow (c) and Scheme V, or the collet chuck (d)

Figure 5 b shows genetic linkage formula (WD chuck for fixing cylindrical parts (CL) in which the axial force (F_{x1}) from the power source (the drive) is converted into a radial (normal to the surface of the part) by (F_{y2}). Structural design and construction chuck clamping, in which the process of clamping the object (tool) is carried out in two stages (I - choice clearances or pre-clip, II- a tightness of the system or the final clip to the desired strength) may have more than one input and one power energy) then as Connect transfer and conversion of different units of performance (Table 3) [6,21].

Table 3
Morphological table kinematics (power flow) Drilling and Milling Chucks

Number		3- type of connection	4- place summing flows
1- input	2- circuits (flows)		
1.1 one	2.1 one	3.1 serial	4.1 input
1.2 two	2.2 two	3.2 parallel	4.2 output
1.3 more than two	2.3 more than two	3.3 parallel-serial	4.3 input and output 4.4 absent

From Table 3 shows that the different structures may CP $N=3 \cdot 3 \cdot 3 \cdot 4=108$. Some of them as we expand the range of diameters of drilling and milling cartridges are given in Table 4, which requires different methods of calculation of their power, and energy characteristics of the kinematic [4,6,9,21].

Table 4
Schemes of chucks and theirs forcing (energizing) streams

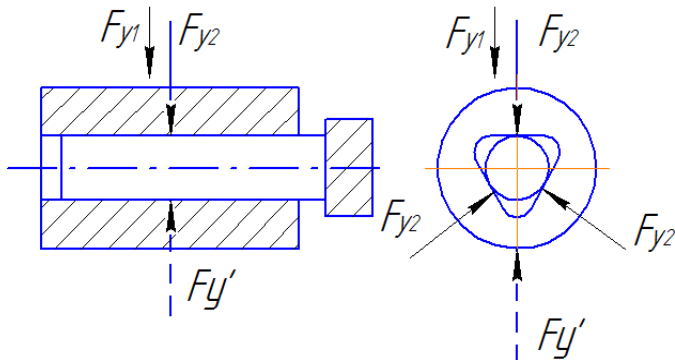
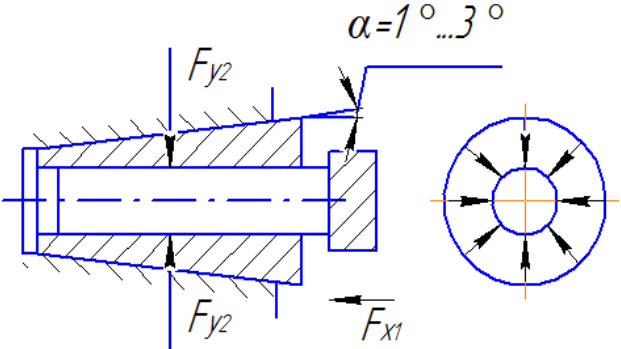
№ structure (fig.1)	Type of chuck	Structural scheme of chuck	Forcing (energizing) stream
1	2	3	4
I	With an elastic solid cylindrical sleeve		$F_{y1} - F_{y2}$
II	With an elastic solid collet		$F_{x1} - F_{y2}$

Continuation of table 4

III	Collet with elastic petals		$F_{x1} - F_{y2}$
IV	Self-adjusting collet		$F_{x1}^c - F_{x1} - F_{y2}$
V	Wide range of collet with a single animation		$F_{x1} - F'_{y1} - F_{y2}$
VI	Wide range of collet double animation		$(F'_{y1} - F''_{y1})$
VII	Collet with threaded sleeve		$M_{x1} - F_{x1} - F_{y2}$

Continuation of table 4

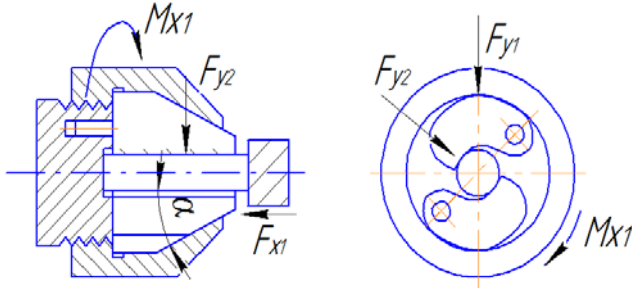
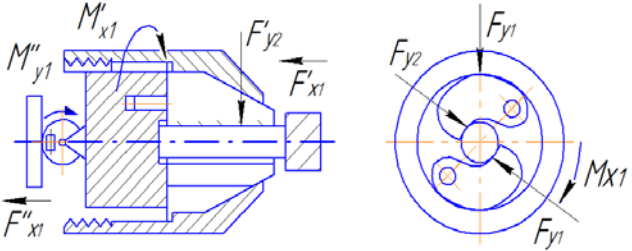
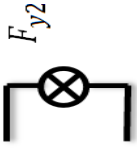
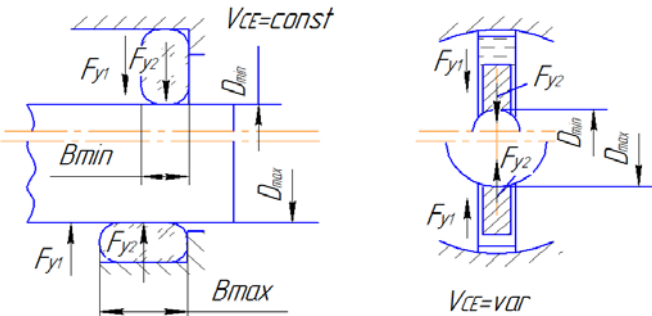
VIII	Widerange eccentric drilling-milling chuck with a kinematic chain		$M_{x1} - F_{x1} - F_{y1} - F_{y2}$
IX	Widerange eccentric drilling-milling chuck with two kinematic chains		 $M'_{x1} - F'_{x1} - F'_{y1} - F'_{y2}$ $M''_{x1} - F''_{x1} - F''_{y1} - F''_{y2}$
X	Wide range of cartridges with a constant (a) and reconfigurable multi-profile cams (b) the volume of the clamping elements		$F_{y1} - F_{y2}$

4. Conclusion.

The genetic classification of energetic (power) flows in the clamping mechanisms of various versions summarizes the properties of the elastic force structures of these mechanisms and constitutes the systematic basis for understanding of the fundamental principles of the structural organization and natural development of mechanical, electromechanical, hydraulic, pneumatic, electromagnetic, magnetic and other force clamp systems such as bodies of rotation similar to the genetic classification of the electromagnetic field primary sources [9].

In the proposed classification of the interaction of the clamping element with the clamping object (components, work pieces or tool) various principles and laws of mechanics are reflected, including the topological invariance principle of

the field sources, the principle of symmetry [8]; the principle of two ness, the principle of conservation of the basic types of mechanical and other energy converters, the law of energy conservation, D'Alembert's principle, Hooke's Law etc.

The proposed approach allows a systematic approach to the creation, testing and forecasting of any mechanical systems, from the genetic level, as illustrated in the clamping mechanism.

Reference

- [1] Balashov, E.P. Evolyutsinnoy synthesis systems / E.P. Balashov - M.: Radio and communication, 1985. –p. 328
- [2] Kuznetsov, Y.N. Dual clamping collets: theory and practice: Monograph / Y.N. Kuznetsov, Guerra J.A. Hamuyela, T.O. Hamuyela - Monograph / Ed. Kuznetsova Y.N. - Kiev, Kiev: Ltd "Gnosis", 2013. - p. 401
- [3] Kuznetsov, Y.N. Morphological synthesis tools and mechanisms: Monograph/ Y.N. Kuznetsov, Guerra J.A. Hamuyela, T.O. Hamuyela - Monograph / Ed. Yuri Kuznetsov - Kiev, Kiev: Ltd "Gnosis", 2012. - p. 416
- [4] Kuznetsov, Y.N. Computer simulation study of power and the characteristics of the eccentric chuck. Y.N. Kuznetsov, Hassan al-Dabas, P.M. Nedelcheva // "Design, manufacture and operation of agricultural machinery", Kirovograd: 2006.-p.p.247-252.
- [5] Kuznetsov, Y.N. System-morphological approach for the synthesis of wide-range of eccentric drilling and milling cartridges /Y.N. Kuznetsov, Hassan al-Dabas, P.M. Nedelcheva // Proceedings on Technical University - Gabrovo, v. 33, 2006.
- [6] Kuznetsov, Y.N. Tool chucks: Monograph. - K.: Ltd "Gnosis", 2012. / Y.N. Kuznetsov , V.N. Voloshin, V. B. Firansky, O. Gumenjuk –p. 286, Ill.
- [7] Kuznetsov, Y.N. Application of Genetic Operators in the synthesis of Collet / Y.N. Kuznetsov, P.M. Nedelcheva, K.Y. Lunyov // International Scientific Conference of UNITEH'09, TU Gabrovo, Bulgaria, 2009. - pp. 99-102.
- [8] Self-adjusting clamp mechanisms: Reference book / Kuznetsov, Y.N., Vachev, A.A. Syarov, S.P., Tsrvenkov, A.J.: Ed. Y.N. Kuznetsov, - K.: Tehnika, Sofia. State Publishing House "Tehnika", 1988. –p. 221
- [9] Urmantsev, Y.A. The symmetry of nature and the nature of symmetry / Urmantsev Y.A. - M.: "Misl", 1974. – p. 229
- [10] Fomenko, A.T. Geometry and Topology. Mathematical images in the real world/ Fomenko A.T. - Moscow: M. Un. Publishing House, 1992. –p. 432
- [11] Timchenko, A.A. Fundamentals of system design and system analysis of complex objects / A. A. Timchenko - K.: Lybid, 2000. –p. 272
- [12] Hubka, V. Theory of technical systems: Monograph /V. Hubka in [Lane. with him.] - Wiley, 1987. –p.208
- [13] Shinkarenko, V.F. The genetic programmes of complex evolving systems/ V.F. Shinkarenko, Y.N. Kuznetsov// Proceedings of the International Conference “UNITEKH'11”, TU - Gabrovo, 2011 vol.2 part 1, 2. – pp.33-54.
- [14] Shynkarenko, V.F. Fundamentals of the theory of electromechanical systems evolution/ V.F. Shynkarenko – K.: Naukova Dumka, 2002. –p. 288
- [15] Yudin, G.E. Systematic approach and activities: Monograph/ G.E. Yudin – M.: Nauka, 1978. –p. 392
- [16] Zwicky, F. Discovery, invention, research through the morphological approach/ F. Zwicky, – Toronto, New York: MeMillan, 1969.

- [17] Bertalauffy, L. Von. General System Theory. Foundational, Development, Applications/ L. Von. Bertalauffy, New York. George Braziller, 1968. – p.368
- [18] Hamuyela, J.A. Guerra. Creation of new clamping mechanisms using genetic-morphological method/ Guerra J.A. Hamuyela, Y.N. Kuznetsov, Ibrahim Al-Refo Farhan // Journal of mechanical Engineering of the National Technical University of Ukraine “Kyiv Polytechnic Institute”, № 67, 2013. – ISSN 2305-9001. – pp. 155 – 162.
- [19] Kuznetsov, Y.N. Theory of technical systems / Y. N. Kuznetsov, Y.K. Novosyolov, I. V. Lutsiv – Sevastopol: Sev NTU, 2012 –p. 256
- [20] Kuznetsov, Y.N., Clamp mechanism for high-speed and high-precision machining / V.N. Voloshin, V.N., Nedelcheva, P.M., F.V. El-Dahab / Monograph - Ed. Y.N. Kuznetsov – Gabrovo: *Vasil Aprilov* University Press, 2010.– p. 724
- [21] Kuznetsov, Y.N., Wideband and multi-clamping mechanisms: theory and practice: Monograph / Y.N. Kuznetsov, V.G. Kushik, O.Y. Yurchishin / Monograph - Ed. Y.N. Kuznetsov - K.: Ltd "ZMOK" - Ltd "GNOSIS", 2011. - p. 424
- [22] Odrin, V.M. Morphological analysis method of the technical systems / V.M. Odrin - M.: “ВНИИПИ”, 1989. – p. 312
- [23] Weisser, W. Flexible Spannsysteme fur die Drehbearbeitung/ W. Weisser // *Industieanzeiger*. – 1979.- № 82. – pp.41-42.
- [24] Acuro. Balancing system for tool holders, grinding wheels and rotors. Operating manual. Schunk GmbH & Co. KG. Lauffen/Necar, 2003.- p. 99
- [25] Leopold, I. Bewertung von HSC – Spann Futterern/ I. Leopold, G. Schmidt // *Werkstatts – technik*. – 2001. – № 9 (91) – pp.556-564.